







\_\_\_\_\_

\_\_\_\_\_

HL-LE003F9VW-20B1C46 (Ra2)

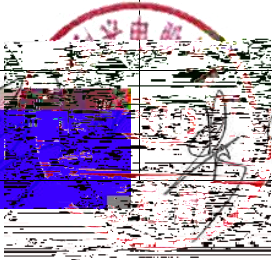
\_\_\_\_\_

Client approval		Hongli approval	
			
			
		2016. 03. 15	

Adr Xianke 1st Rd, Huadong Town, Huadu Dist., Guangzhou, China

1

Tel/ 020-86733333 Fax/ 020-86733883 86733938

Web/ www.honglitronic.com

- 1.
- 2.
- 3.

**High Power AC LED Module**  
**P/N: HL-LE003F9VW-20B1C46(Ra2)**

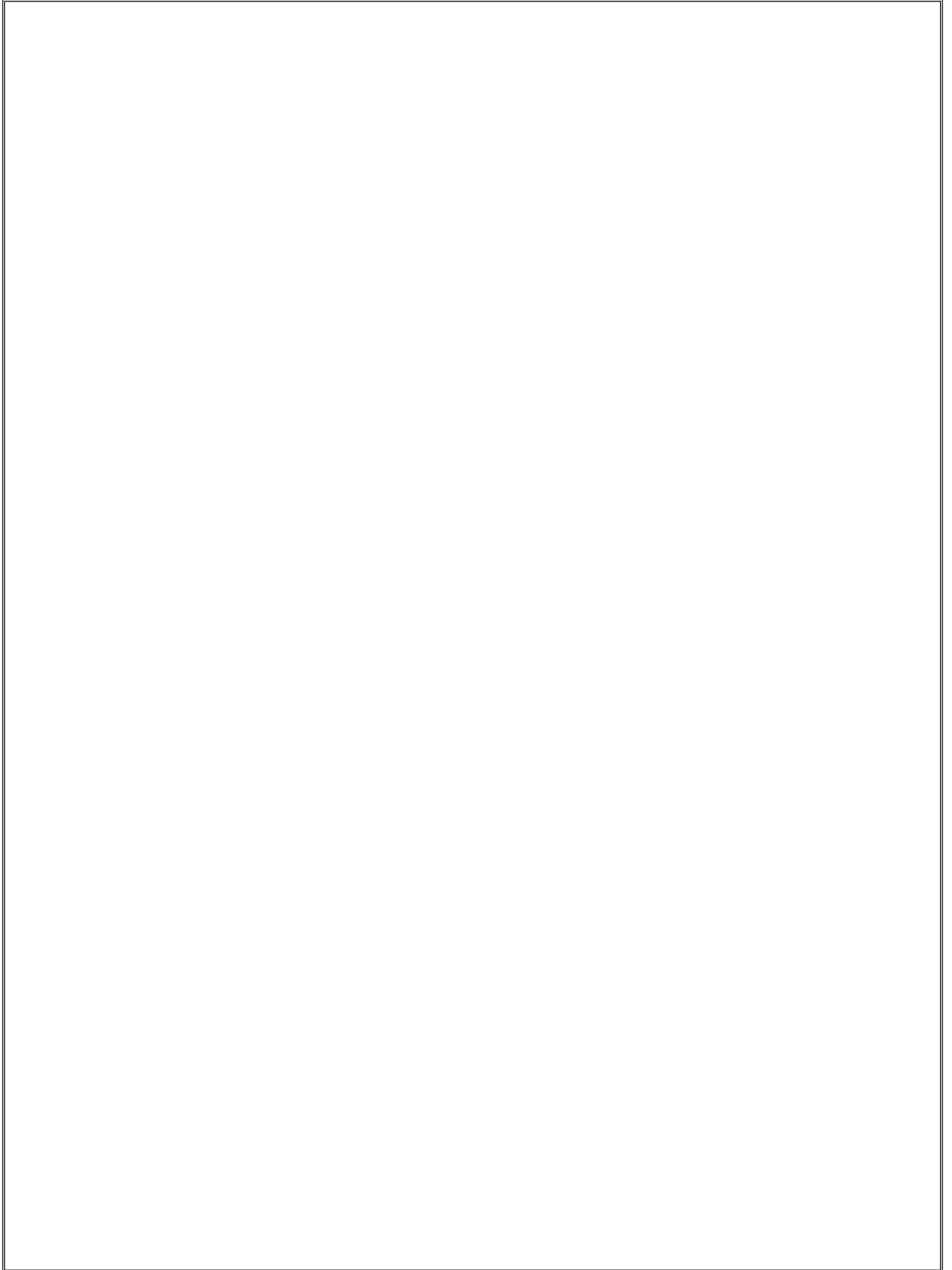

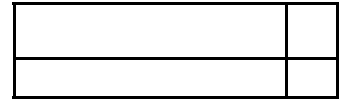

### 4.Package Dimensions

Tolerance unless otherwise specified: ±0.3mm.

±0.3

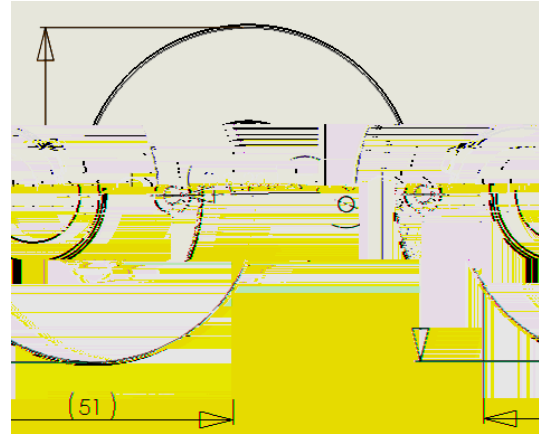
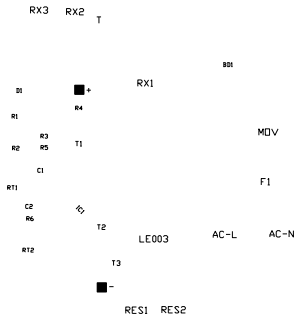

### 5.Performance

#### (1) Absolute Maximum Ratings

Parameter	Symbol	Rating Value	Units
Maximum Voltage	$V_{OPT}$	250	V [RMS]
Power Dissipation	$P_D$	22	W
Junction Temperature (1)	$T_j$ LED	120	
	$T_j$ -IC	125	
Top of the IC temperature IC	$T_p$	100	
Operating Temperature Range	$T_{op}$	-	
Storage Temperature Range	$T_{stg}$	-	
ESD Sensitivity	ESD		
Lead Soldering Temperature*	$T_{sol}$		

**Notes for Table**

1 The capacity of heat sink  $T_{j-ic} < 125$

$$T_{j-ic} = T_p + P_{ic} * R_{ic} \quad P_{ic} = 2.5W \quad R_{ic} = 9 \text{ /W} \quad T_p \text{ surface temperature of IC}$$

$$T_{j-ic} < 125$$

$$T_{j-ic} = T_p + P_{ic} * R_{ic} \quad P_{ic} = 2.5W \quad R_{ic} = 9 \text{ /W} \quad T_p \text{ IC}$$

(2) All extreme conditions need to be satisfied.





**(2) Electro-Optical Characteristics**  
**Tc=25°C**

**at Tc=25°C**

Parameter	Symbol	Condition	Min.	Typ.	Max.	Unit
Operating Voltage	$V_{OPT}$					



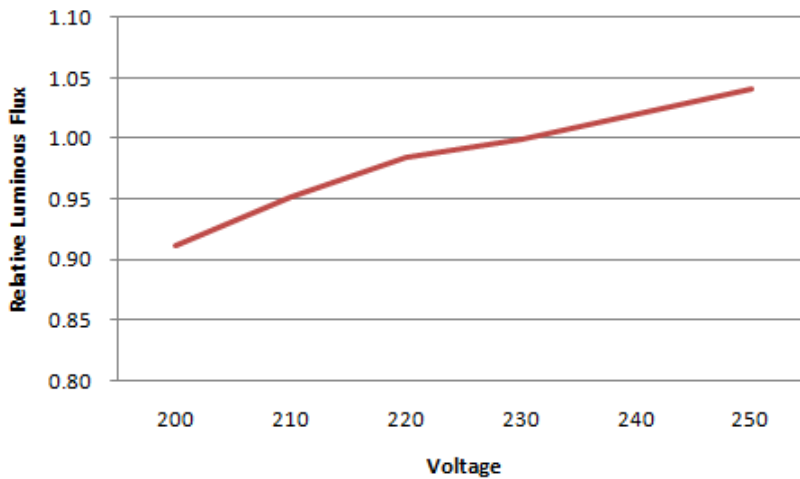
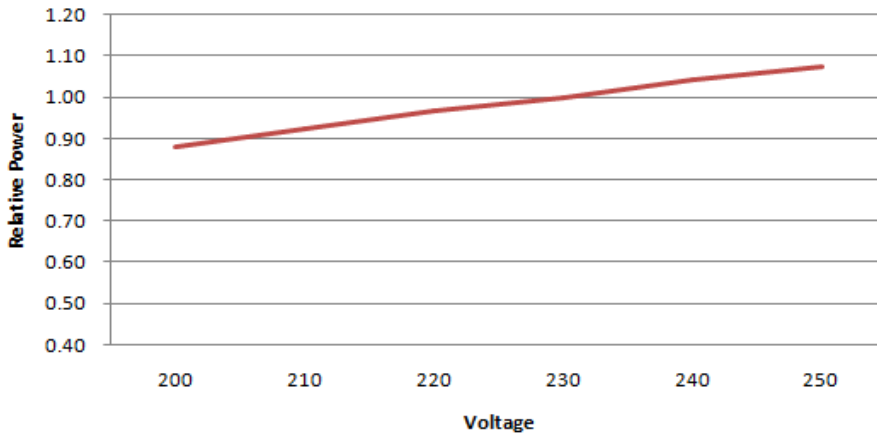
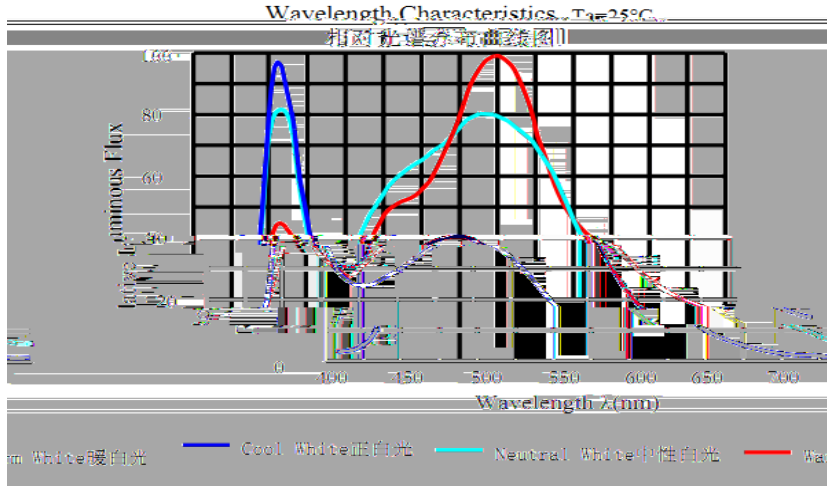

### 6.Characteristics





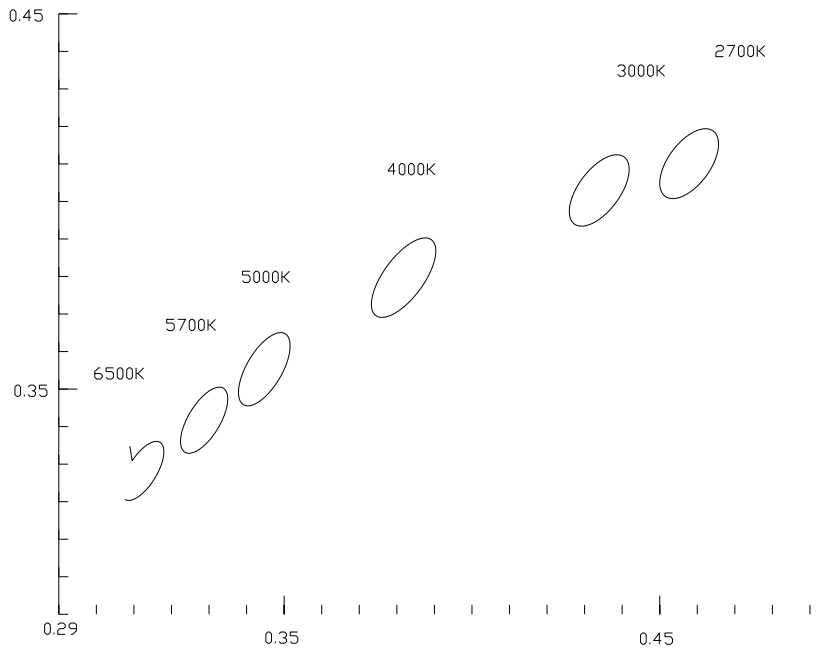

### 7.Product bins

#### Chromaticity bins

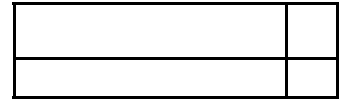

Notes

1



### 8.Packing Specifications

 HONGLITRONIC 鸿利光电		
TYPE:		QTY:
VF:		φV:
TC:	X/Y:	
SDCM<	Ra:	
DATE:--	LOT.NO:--	

 HONGLITRONIC 鸿利光电		成品标示卡 (Product Identity Card)
		
品名(Description):	High Power LEDs	
产品型号(Type):	XXXXXXXX XXXXXXXX	
发光颜色(Color):	XXXXXX	
数量(QTY):	XXXXK	
生产批号(LOT NO):	XXXXXXXX XXXXXXXX	
出货日期(Date):	XXXX.XX.XX	
操作员(Operator):	XXXX	

#### Packing figure

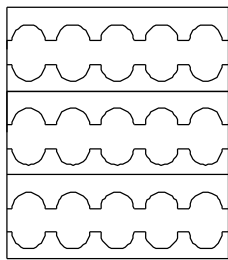

Tray: 15pcs

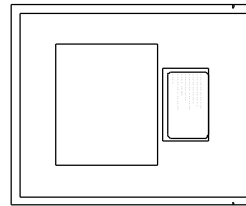
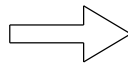

2Tray/ESD Shilding Bag: 30p cs

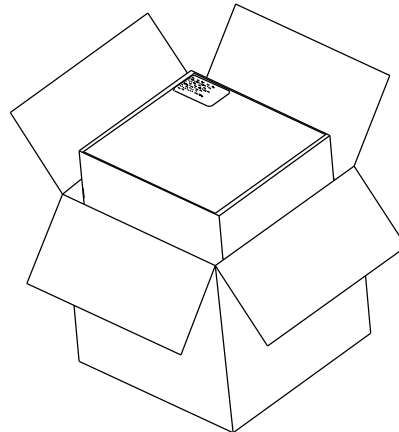

3ESD Shilding Bag/Inner Box: 90pcs

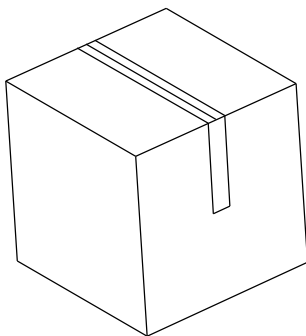
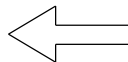

4Inner Box/Outer Box:360pcs



## Precautions ( )

### 1. Storage

To avoid moisture, we recommend storage conditions for the unopened LED

ing the package. Please make sure to dehumidify and vacuum pack the remaining/

for the sealed led is one year.

5-

60% LED 168H

4H

### 2. The soldering precautions

During assembly, please ensure that a good quality thermal paste is applied and distributed evenly over the surface. While using thermal pad (Heat Sink), make sure LED is firmly tightened and there is no gap between surfaces.







Please make sure of not getting short during the welding process.

Due to connecting high voltage, pay attention to safety when installing and/or testing.

Do not touch the module without any reasonable ESD protection while circuit is active.

PCB

Hot-plug test is not recommended

3 Cautions for use

The module is recommended to apply in indoor lighting Before using altered specifications other than recommended, please consider risk factors.

Faults, lightning, or switching transients can cause voltage surges in excess of the normal ratings.

Internal component failure can cause excessive voltages.

Electrical Over-Stress (EOS) is defined as damage that may occur when an electronic device is subjected to a current or voltage that is beyond the maximum specification limits of the device.

EOS



4 Anti-Static Measures

Please take adequate measures to prevent electrostatic generation, such as wearing electrostatic ring or anti-static fingerstall etc; any relative products like plant equipment, machinery, carrier and transportation units shall be connected to discharging unit/ ground. The ESD sensitivity of this product is > 1000V, after assembly the final lamp, please make sure to discharge Static Electricity by proper ESD equipment.

1000V

S

LED

5. Temperature Control

Recommended temperature conditions for enhanced product life: Be sure to Tp

Tp

IC

COB

6. Other

Product is not suitable to use in following conditions

Touch the silicone resin area with sharp objects such as pincett (tweezers).

Excessive force more than 3000gf on the silicone lens.

3000gf

Cover the silicone resin area with any other resins such as epoxy, urthane, etc

Assemble/use in conditions of high moisture and/or strong oxidizing gas such as Cl, H<sub>2</sub>S, NH<sub>3</sub>, SO<sub>2</sub>, NO<sub>x</sub>, etc.

Cl, H<sub>2</sub>S, NH<sub>3</sub>, SO<sub>2</sub>, NO<sub>x</sub>

Use with substance containing sulfur.

Long time exposure to sunlight or UV can cause silicone discolored.

UV

Exposed to dust, liquids or oils.