

HVO-3528DER

3528 PLCC4

Products Series

High luminous efficiency, consistency, stability and reliability, it is mainly used in automobile applications.

- PPA
- 50% I_v 120
- 606nm
- AEC-Q19422f1 0 0 1 172Tm(-) TJET EMC /P /MCID 44 BDC BT51 0 9.96u96 12 &1 4032E 0

Ordering Information

Type	Luminous Intensity I _v @ I _f =50mA	Ordering Code
HVO-3528DER - XXXX - XX - XXXX Brightness Color Forward Voltage	1.80 - 5.60 cd	XXXXXX

- HVO-3528DER-BADA-XX-XXXX

4

BA BB CA CB DA
- HVO-3528DER-XXXX-24-XXXX

4

2 3 4
- HVO-3528DER-XXXX-XX-3A4B

4

3A 3B 4A 4B

Note

■ Brightness Grouping

Only one brightness group will be packed in one reel. Please refer to page #4 for details.
E.g.: HVO-3528DER-BADA-XX-XXXX, means only one bin of BA, BB, CA, CB or DA is in one reel.

■ Color Groups

Only one color group will be packed in one reel. Please refer to page #4 for details.
E.g.: HVO-3528DER-XXXX-24-XXXX, means only one bin of 2, 3 or 4 is in one reel.

■ Forward Voltage Groups

Only one forward voltage group will be packed in one reel. Please refer to page #4 for details.

E.g.: HVO-3528DER-XXXX-XX-3A4B, means only one bin of 3A, 3B, 4A or 4B is in one reel.

Maximum Ratings

Parameters	Symbol	Rating	Unit
Junction Temperature	T_j	125	
Forward Current ($T_s=25$)	I_f	70	mA
Peak Forward Current ($t \leq 10\mu s$ $D=0.005$ $T_s=25$)	I_{fp}	100	mA
Reverse Voltage ($T_s=25$)	V_r	12	V
Electrostatic Discharge (HBM)	V_{ESD}	2000	V
Operating Temperature	T_{opr}	-40 ~ +100	
Storage Temperature	T_{stg}	-40 ~ +100	

Characteristics ($T_s = 25$ $I_f = 50$ mA)

Parameters	Symbol	Rating	Unit
Wavelength at Peak Emission	typ. λ_{peak}	610	nm
Dominant Wavelength	min. λ_{dom}	600	nm
	typ. λ_{dom}	606	nm
	max. λ_{dom}	609	nm
Spectral Bandwidth at 50% I_{rel} max	typ.	17	nm
50 % I_v Viewing Angle at 50 % I_v	typ.	120	
Forward Voltage	min. V_f	1.90	V
	typ. V_f	2.15	V
	max. V_f	2.50	V
Reverse Current ($V_R=12V$)	typ. I_r	0.2	μA
	max. I_r	10	μA
PN - Real Thermal Resistance (Junction / Ambient)	max. $R_{th JA_{real}}$	300	K/W
PN - Real Thermal Resistance (Junction / Solder Point)	max. $R_{th JS_{real}}$	130	K/W

Brightness Grouping (T_s 5 $f = 50$ mA)

Grouping	Luminous Intensity I_v min.	Luminous Intensity I_v max.	Luminous Flux Φ_v typ.
BA	1.80 cd	2.24 cd	6.10 lm
BB	2.24 cd	2.80 cd	7.60 lm
CA	2.80 cd	3.55 cd	9.50 lm
CB	3.55 cd	4.50 cd	12.10 lm
DA	4.50 cd	5.60 cd	15.20 lm

Forward Voltage Grouping (T_s 5 $f = 50$ mA)

Grouping	Forward Voltage V_f min.	Forward Voltage V_f max.
3A	1.90 V	2.05 V
3B	2.05 V	2.20 V
4A	2.20 V	2.35 V
4B	2.35 V	2.50 V

Dominant Wavelength Grouping (T_s 5 $f = 50$ mA)

Grouping	Dominant Wavelength λ_{dom} min.	Dominant Wavelength λ_{dom} max.
2	600 nm	603 nm
3	603 nm	606 nm
4	606 nm	609 nm

Information on Label

E.g. BA-2-3A

Brightness	Color	Forward Voltage
BA	2	3A

$$- V(\lambda) =$$

Relative Spectral Emission - $V(\lambda)$ = Standard Eye Response Curve

$$I_{rel} = f(\lambda); T_s = 5 \text{ ms}; I_f = 50 \text{ mA}$$

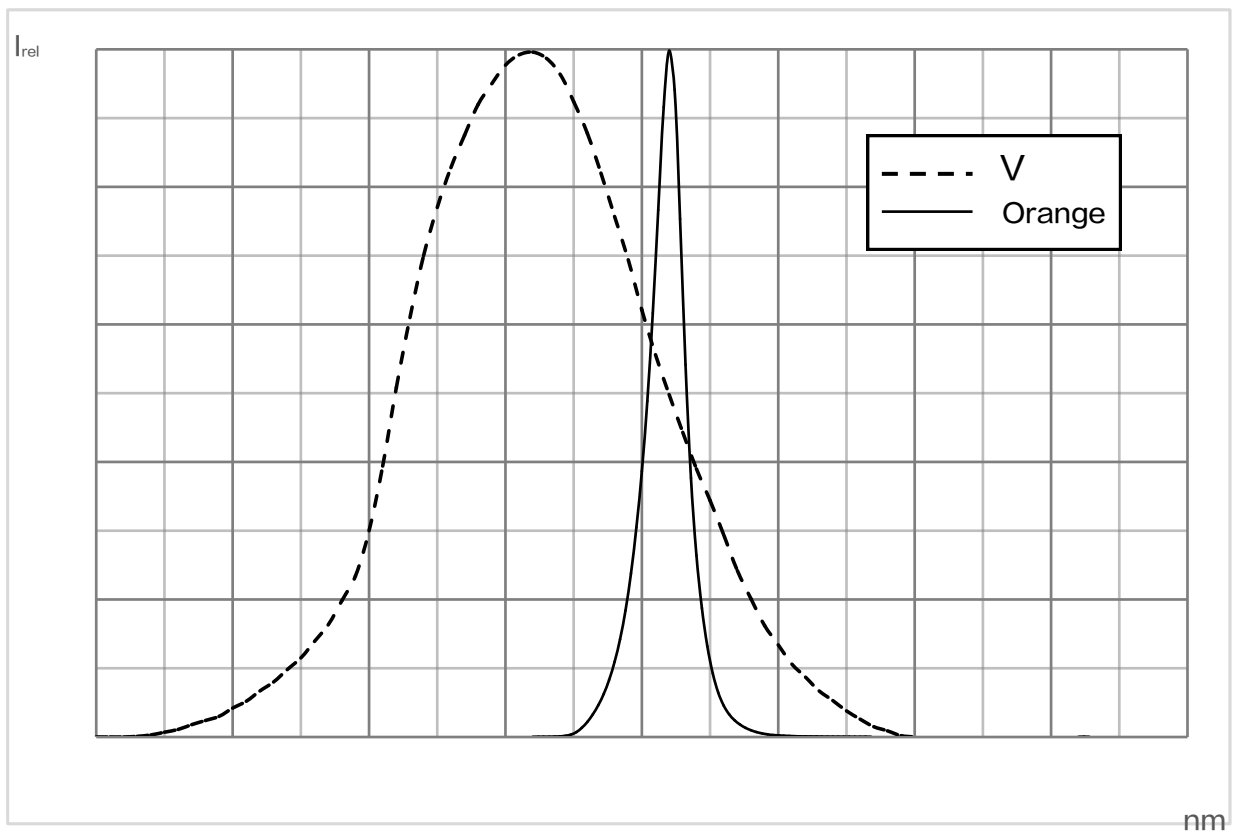

Radiation Characteristics

$I_{rel} = f (T_s = 25$

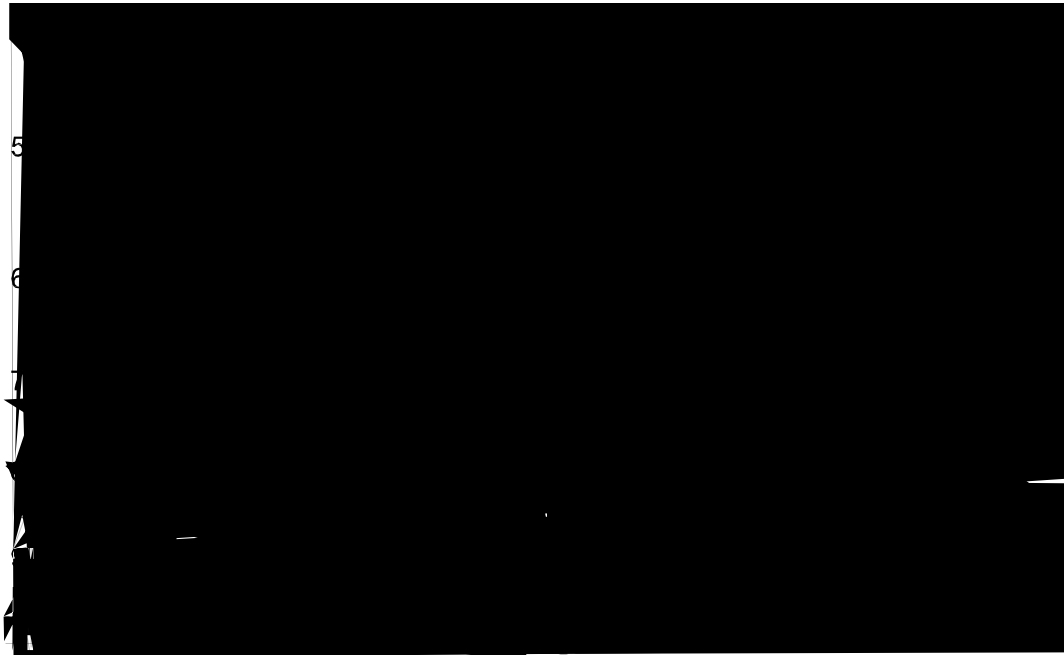

Forward Current

$I_f = f (V_f); T_a 5$

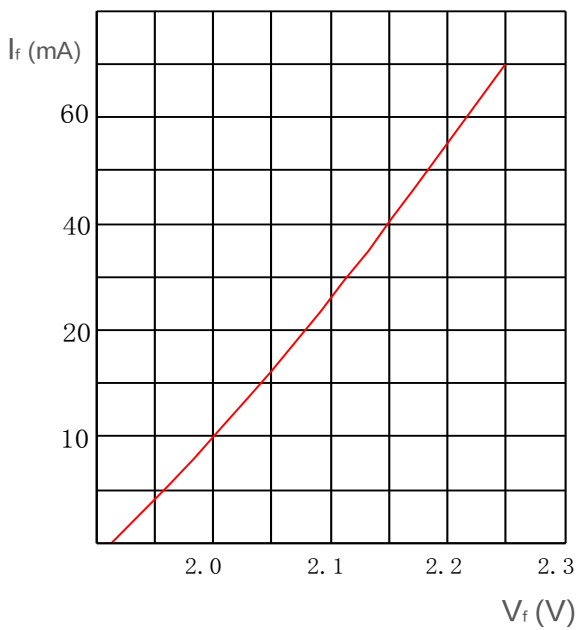

Relative Luminous Intensity

$I_v / I_v(50 \text{ mA}) = f (I_f); T_a 5$

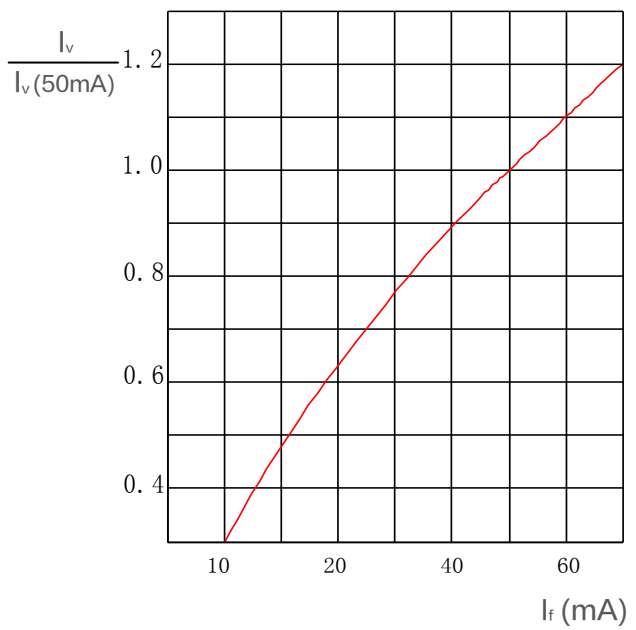

Relative Forward Voltage

$V_f = V_f - V_f$ 5 ; $I_f = 50 \text{ mA}$

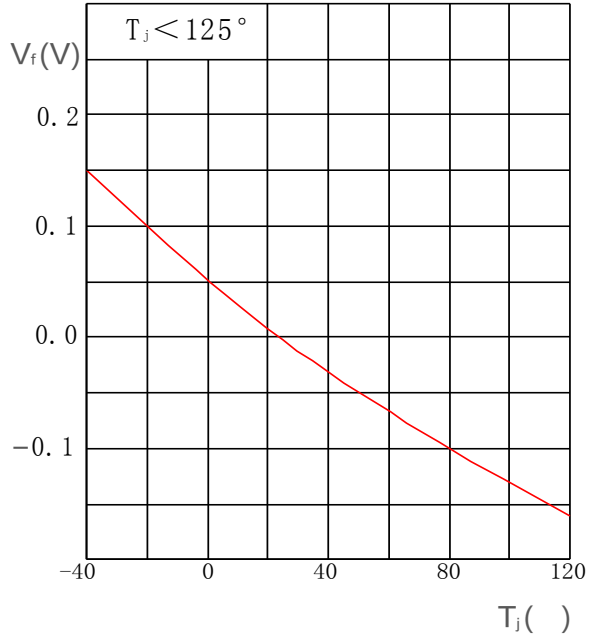

Relative Luminous Intensity

I_v/I_v 5 ; $I_f = 50 \text{ mA}$

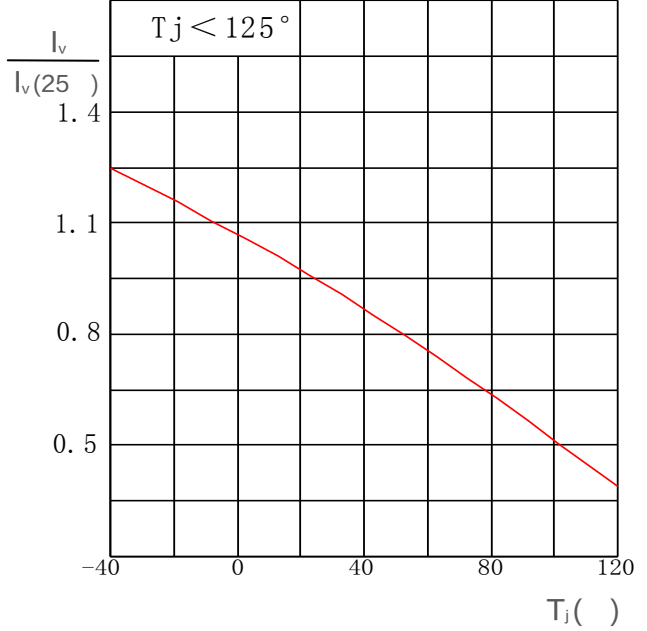

Solder Point Temperature

Ambient Temperature vs. Forward Current

$I_f = f(T_a)$

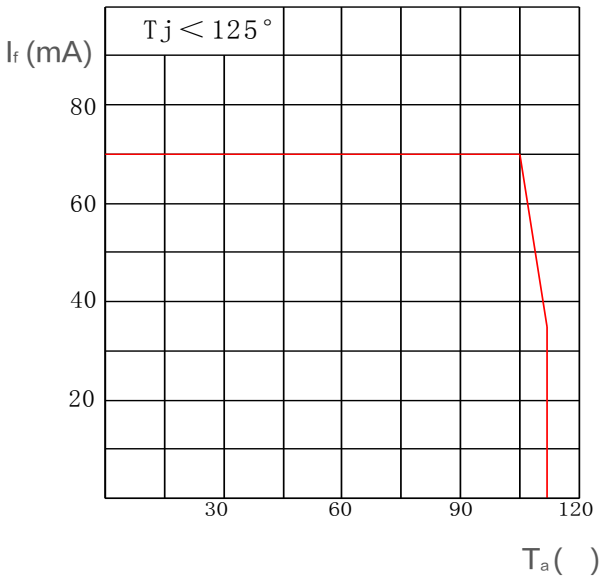

vs. Forward Current

$I_f = f(T_s)$

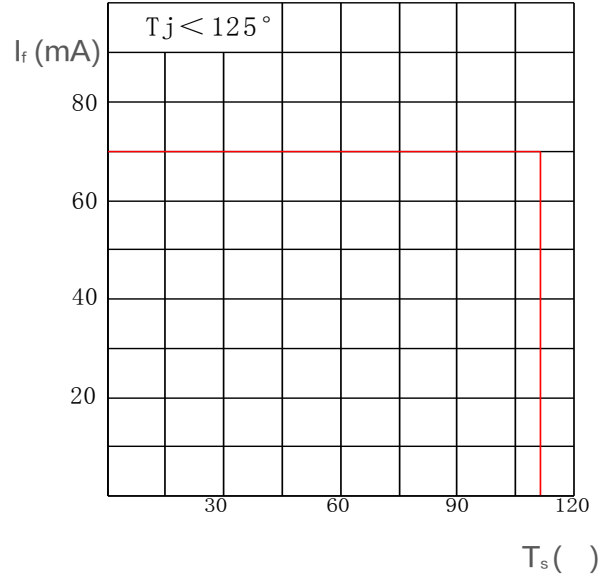

Package Outline

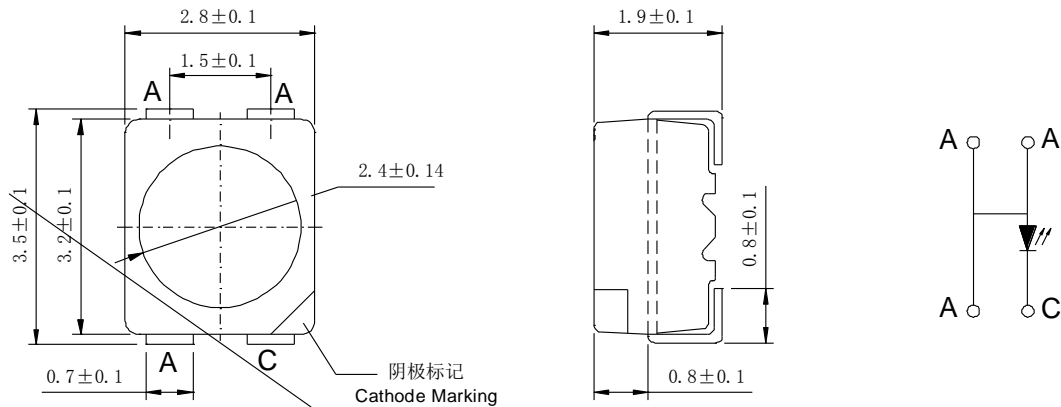

- 30mg
- Class 3B
- : 1) H₂S , hhe , 336 IEC 60068-2-43)
- 2) 2 / IEC 60068-2-60 4: 10ppb H₂S, 200ppb SO₂, 200ppb NO₂, 10ppb Cl₂)

NOTE

- Approximate Weight: 30mg
- Mark: Cathode
- Corrosion test: Class 3B
- Test conditions: 1) H₂S test , , 15ppm, 336hours (Standards IEC 60068-2-43)
- 2) Flowing e a 2 / g (Standards IEC 60068-2-60 test method 4: 10ppb H₂S, 200ppb SO₂, 200ppb NO₂, 10ppb Cl₂)

Recommended Solder Pad

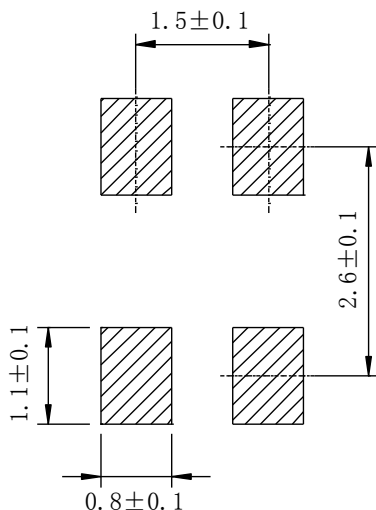

- NOTE
- Package not suitable for ultrasonic cleaning

Reflow Soldering Profile

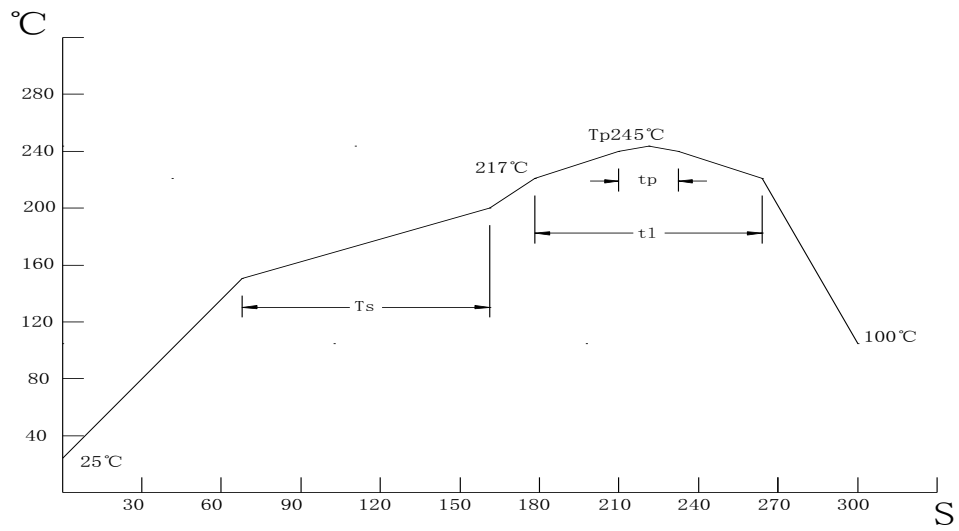

Profile Feature	Symbol	Pb-Free (SnAgCu) Assembly		Unit
		min.	rec.	

Tape and Reel

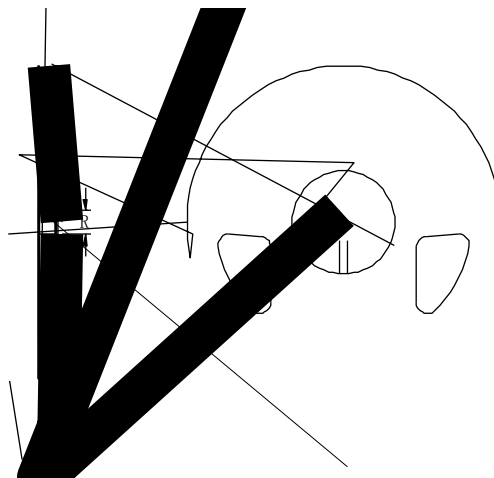
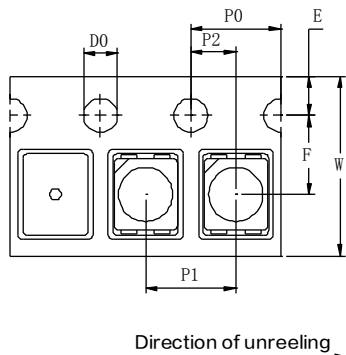

2 400 mm

2 160 mm

IEC 60286-3, EIA 481-

D

Leader: min. 400 mm Trailer: min. 160 mm Requirement acc. to IEC 60286-3, EIA 481-D

Tape Dimensions mm

W	P0	P1	P2	D0	E	F
8 0.1	4 0.1	4 0.1	2 0.05	1.5 0.1	1.75 0.1	3.5 0.05

Reel Dimensions mm

A	W1	W2	N	R
177.8	9.3 0.3	11.2 0.3	58.5 0.2	13.5 0.2

Barcode-Product-Label (BPL)

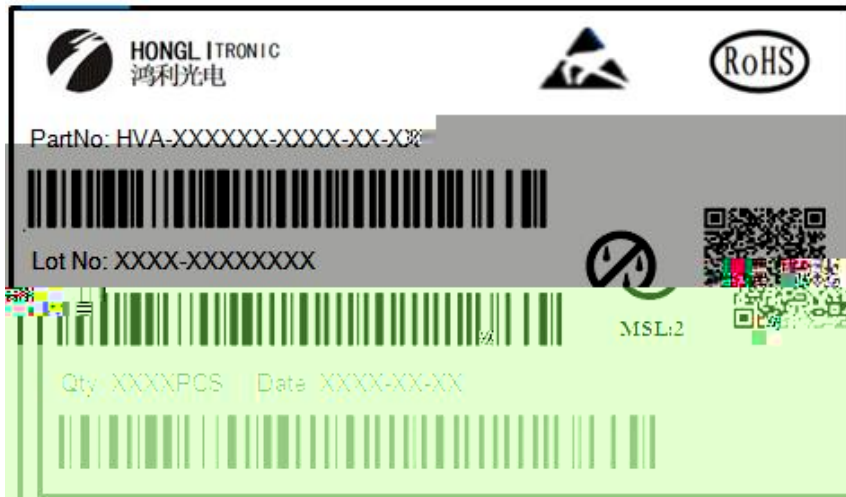

Dry Packing Process and Materials

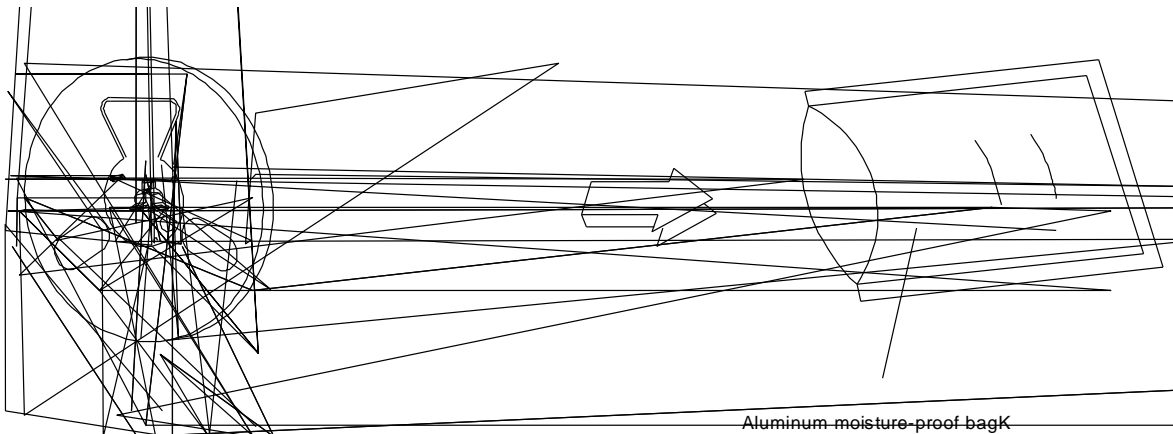

NOTE

JEDEC

Moisture-sensitive product is packed in a dry bag containing desiccant and HIC (humidity indicator card). Regarding dry pack you may find further information in the internet or JEDEC.

Transportation Packing and Materials

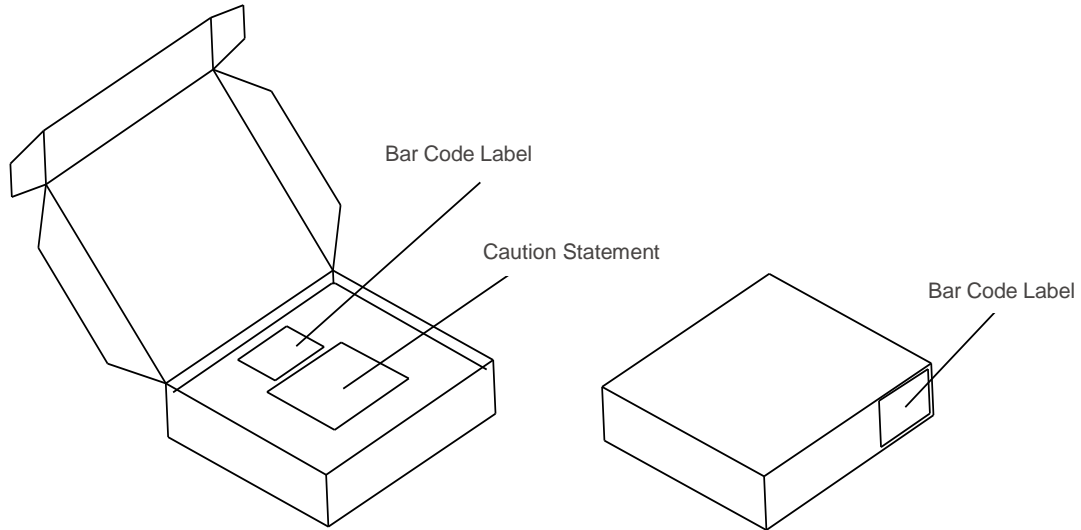

Dimensions of Transportation Box (mm)

Width	Length	Height
256 5	223 5	62 5
256 5	223 5	124 5

:			
:	,	e e	
	8ms	0.05V	0.1V
	GUM K=3		
	25ms	0.5nm	1nm
	GUM K=3		
	25ms	8%	11%
	GUM K=3		

Glossary

Typical Values