

# HVR-3528DER



## 3528 PLCC4 / Products Series

High luminous efficiency, consistency, stability and reliability, it is mainly used in automobile applications.

- PPA
- 50% I<sub>v</sub> 120°
- 625nm
- AEC-Q102 & IEC 60810

### Features

- Package Colorless clear resin in white PPA cup
- Viewing angle at 50% I<sub>v</sub>: 120°
- Color: Red (625nm)
- Qualifications: Passed reliability test per AEC-Q102 & IEC 60810 requirement

### Applications

- Signaling
- Interior and exterior lighting for automotive

/

## /Maximum Ratings

Parameters	Symbol	Rating	Unit
/ Junction Temperature	$T_j$	125	
/ Forward Current ( $T_s=25$ )	$I_f$	70	mA
Peak Forward Current ( $t \leq 10\mu s$ $D=0.005$ $T_s=25$ )	$I_{fp}$	100	mA
/ Reverse Voltage ( $T_s=25$ )	$V_r$	12	V
Electrostatic Discharge (HBM)	$V_{ESD}$	2000	V
/ Operating Temperature	$T_{opr}$	-40 ~ +100	
/ Storage Temperature	$T_{stg}$	-40 ~ +100	

/Characteristics ( $T_s = 25$  ;  $I_f = 50$  mA)

Parameters	Symbol	Rating	Unit
/ Wavelength at Peak Emission	typ. $\lambda_{peak}$	634	nm
/ Dominant Wavelength	min. $\lambda_{dom}$	620	nm
	typ. $\lambda_{dom}$	625	nm
	max. $\lambda_{dom}$	630	nm
/ Spectral Bandwidth at 50% $I_{rel}$ max	typ.	19	nm
50 % $I_v$ / Viewing Angle at 50 % $I_v$	typ.	120	°
/ Forward Voltage	min. $V_f$	1.90	V
	typ. $V_f$	2.15	V
	max. $V_f$	2.50	V
/ Reverse Current ( $V_R=12V$ )	typ. $I_r$	0.2	uA
	max. $I_r$	10	uA
PN - / Real Thermal Resistance (Junction / Ambient)	max. $R_{th JA_{real}}$	300	K/W
PN - / Real Thermal Resistance (Junction / Solder Point)	max. $R_{th JS_{real}}$	130	K/W

/Brightness Grouping ( $T_s = 25$  ;  $I_f = 50$  mA)

Grouping	Luminous Intensity $I_v$ min.	Luminous Intensity $I_v$ max.	Luminous Flux $\Phi_v$ typ.
AB	1.40 cd	1.80 cd	4.80 lm
BA	1.80 cd	2.24 cd	6.10 lm
BB	2.24 cd	2.80 cd	7.60 lm
CA	2.80 cd	3.55 cd	9.50 lm

/Forward Voltage Grouping ( $T_s = 25$  ;  $I_f = 50$  mA)

Grouping	Forward Voltage $V_f$ min.	Forward Voltage $V_f$ max.
3A	1.90 V	2.05 V
3B	2.05 V	2.20 V
4A	2.20 V	2.35 V
4B	2.35 V	2.50 V

/Dominant Wavelength Grouping ( $T_s = 25$  ;  $I_f = 50$  mA)

Grouping	Dominant Wavelength $\lambda_{dom}$ min.	Dominant Wavelength $\lambda_{dom}$ max.
1	620 nm	630 nm

## /Information on Label

/E.g. BA-1-3A

/Brightness	/Color	/Forward Voltage
BA	1	3A

-  $V(\lambda) =$

Relative Spectral Emission -  $V(\lambda) =$  Standard Eye Response Curve

$I_{rel} = f(\lambda)$ ;  $T_s = 25^\circ\text{C}$ ;  $I_f = 50\text{ mA}$

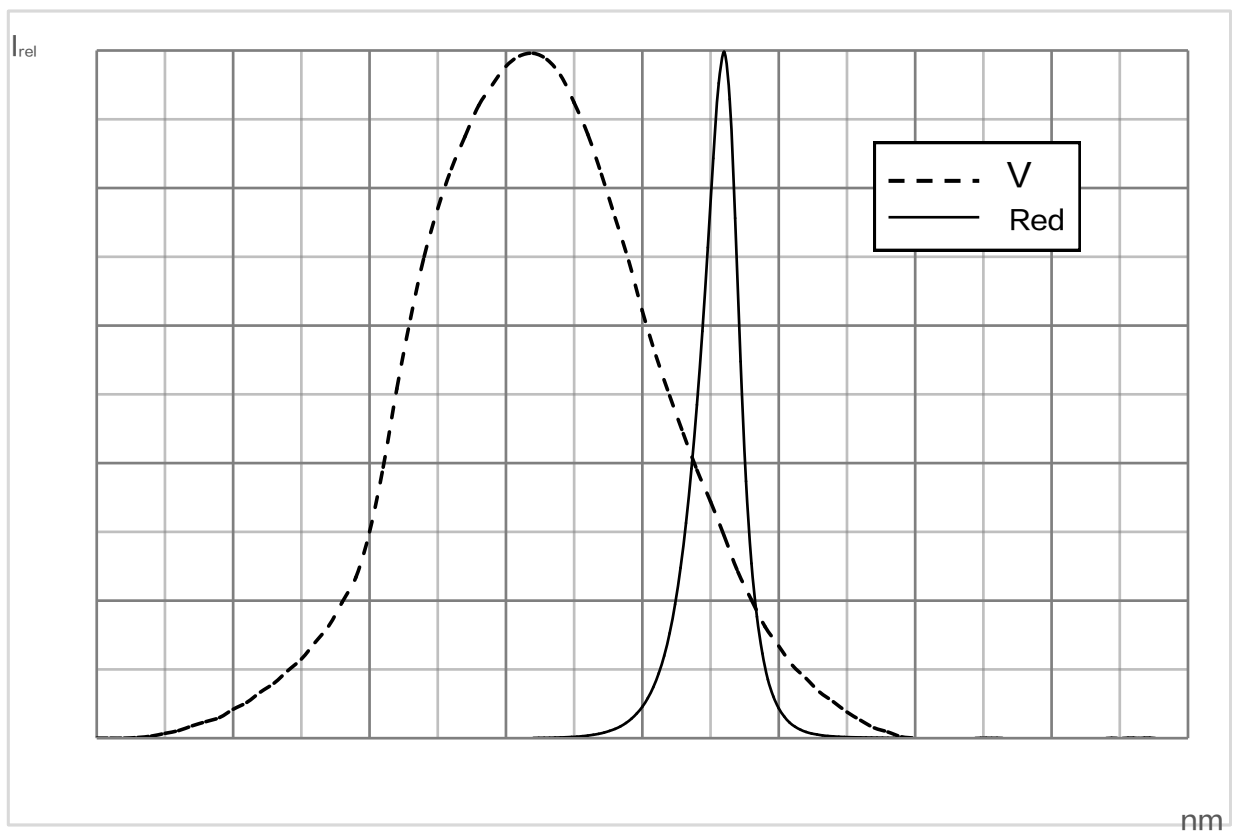

/Radiation Characteristics

$I_{rel} = f(\theta); T_s = 25$

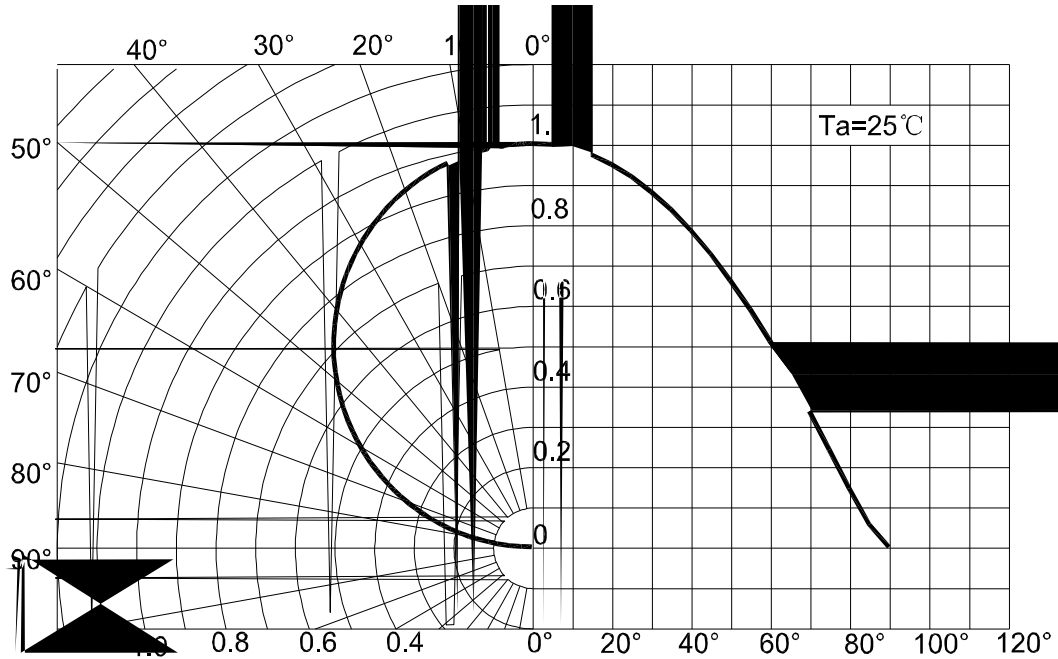

/Forward Current

$I_f = f(V_f); T_a = 25$

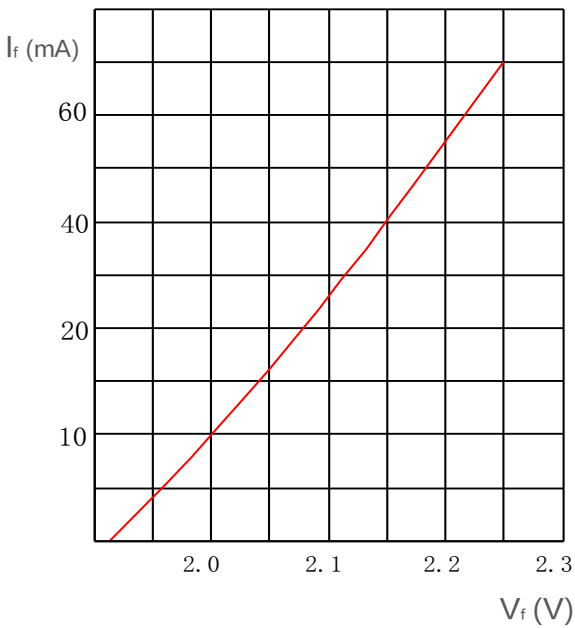

/Relative Luminous Intensity

$I_v/I_v(50\text{ mA}) = f(I_f); T_a = 25$

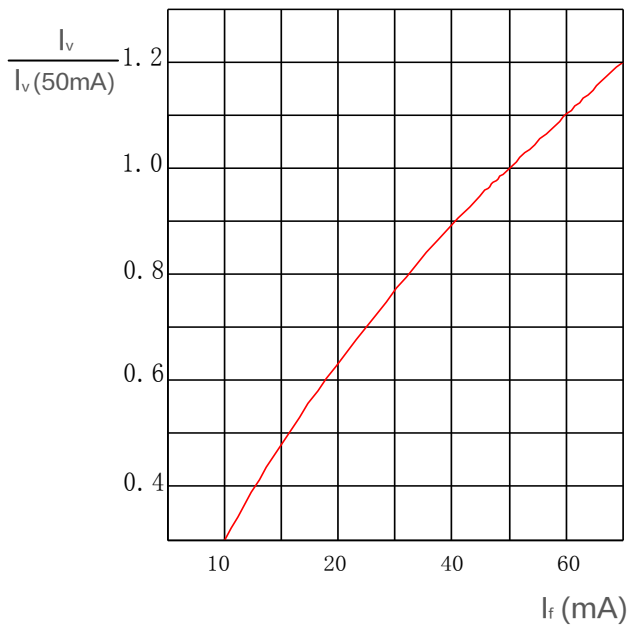

/Relative Forward Voltage

$V_f = V_f - V_f(25^\circ) = f(T_j); I_f = 50 \text{ mA}$

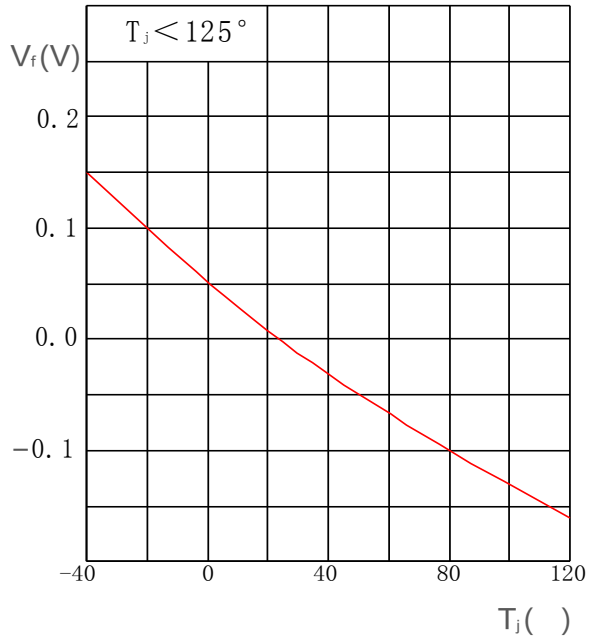

/Relative Luminous Intensity

$I_v/I_v(25^\circ) = f(T_j); I_f = 50 \text{ mA}$

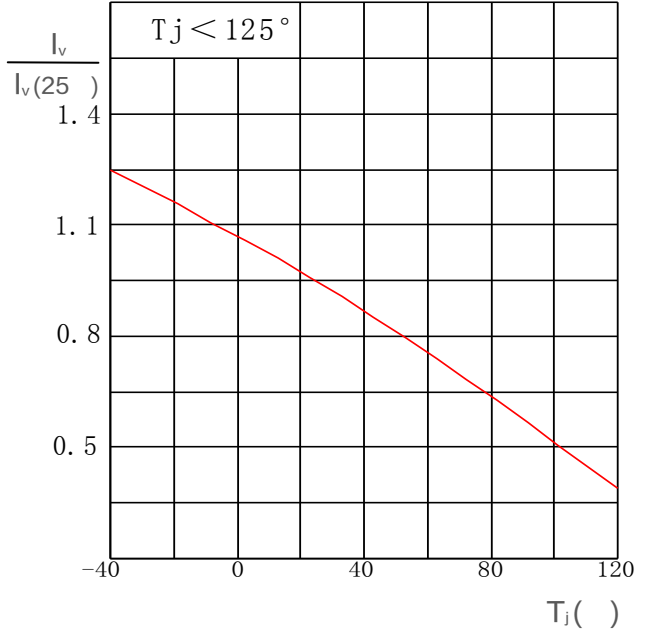

Ambient Temperature vs. Forward Current  
 $I_f = f(T_a)$

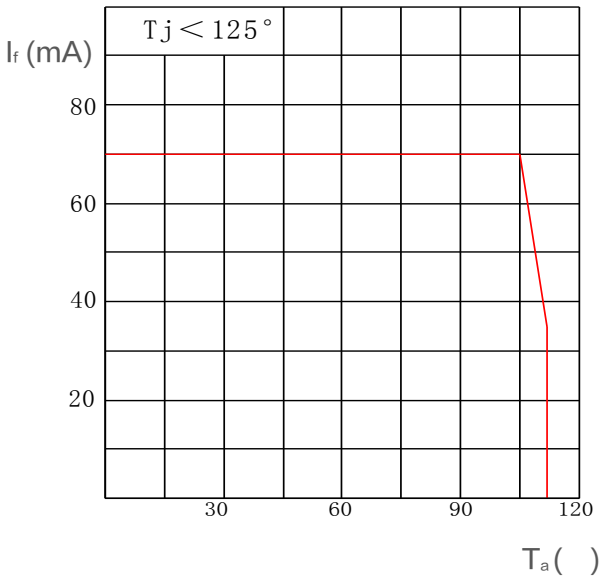

/Solder Point Temperature vs. Forward Current  
 $I_f = f(T_s)$

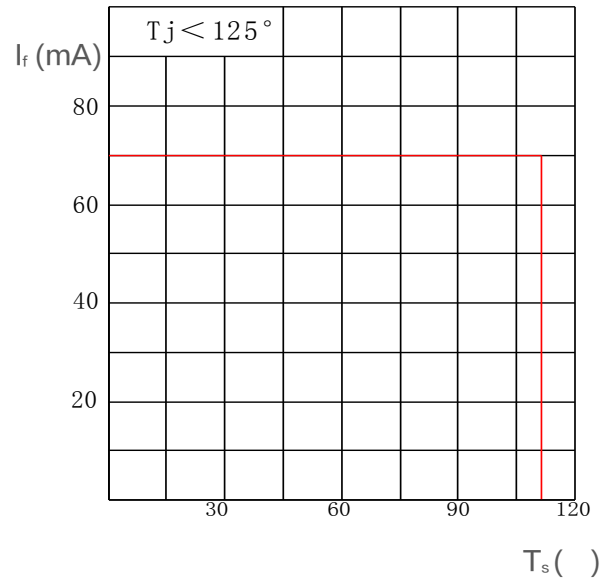

## /Package Outline

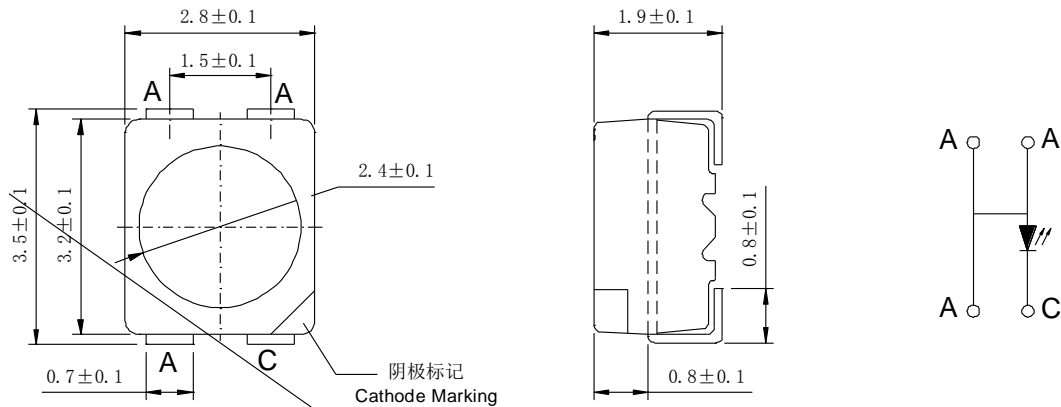

- 30mg
- Class 3B
- : 1) H<sub>2</sub>S 40 /90% R.H, 15ppm, 336 ( IEC 60068-2-43)
- 2) : 25 /75 % R.H, 500
- ( IEC 60068-2-60 4: 10ppb H<sub>2</sub>S, 200ppb SO<sub>2</sub>, 200ppb NO<sub>2</sub>, 10ppb Cl<sub>2</sub>)

### NOTE

- Approximate Weight: 30mg
- Mark: Cathode
- Corrosion test: Class 3B
- Test conditions: 1) H<sub>2</sub>S test 40 /90% R.H, 15ppm, 336hours  
(Standards IEC 60068-2-43)
- 2) Flowing mixed gas test: 25 /75 % R.H, 500hours  
(Standards IEC 60068-2-60 test method 4: 10ppb H<sub>2</sub>S, 200ppb SO<sub>2</sub>, 200ppb NO<sub>2</sub>, 10ppb Cl<sub>2</sub>)

## /Recommended Solder Pad

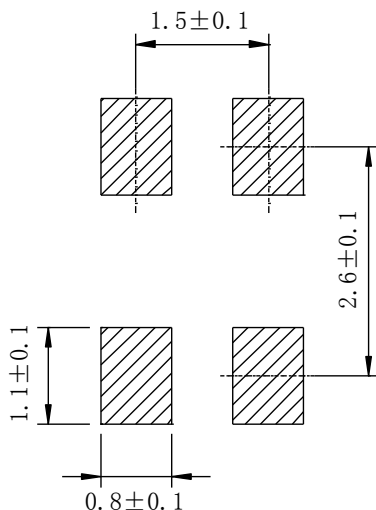

- NOTE
- Package not suitable for ultrasonic cleaning



## / Reflow Soldering Profile

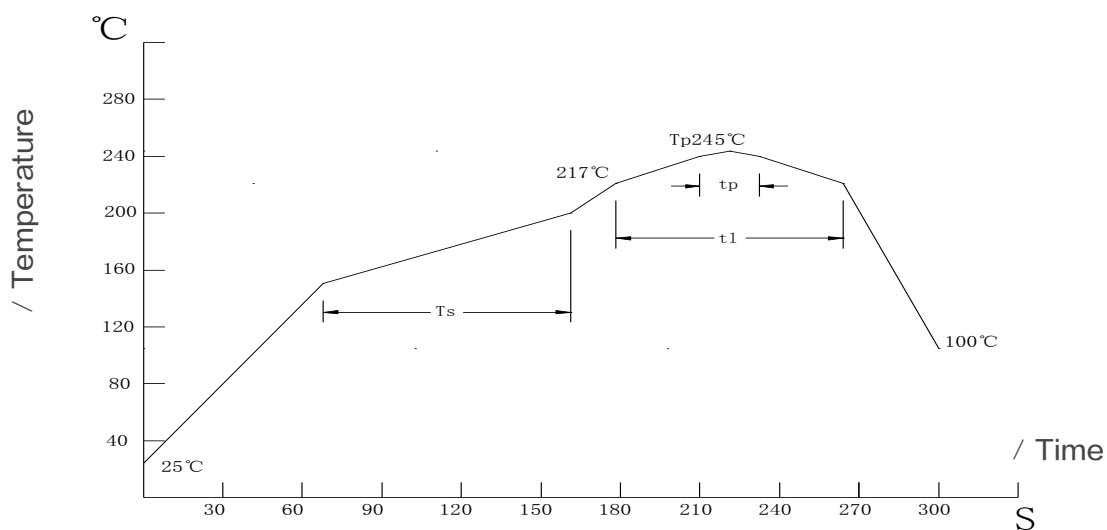

Profile Feature	Symbol	Pb-Free (SnAgCu) Assembly			Unit
		min.	rec.	max.	
Ramp-up Rate to Preheat 25 -150	-	-	2	3	/s
/Time $T_{smin}$ to $T_{smax}$	$T_s$	60	100	120	s
Ramp-up Rate to Peak $T_{smax}$ to $T_p$	-	-	2	3	/s
Liquidus Temperature	$T_l$	-	217	-	-
Time above Liquidus Temperature	$t_l$	-	80	100	s
/Peak Temperature $\pm 5$	$T_p$	-	245	260	-
Time within 5 of the Specified Peak Temperature	$t_p$	10	20	30	s
/Ramp-down Rate $T_p$ to 100	-	-	3	6	/s
/Time 25 to $T_p$	-	-	-	480	s

/Tape and Reel

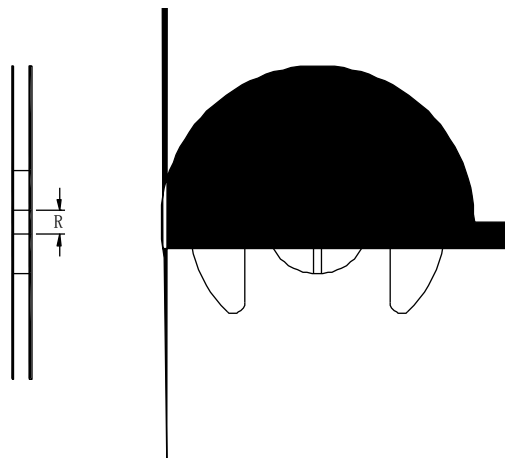
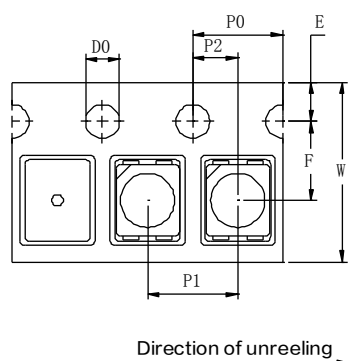

W : 400 mm      P1 : 160 mm      IEC 60286-3, EIA 481-D

Leader: min. 400 mm    Trailer: min. 160 mm    Requirement acc. to IEC 60286-3, EIA 481-D

/Tape Dimensions    mm

W	P0	P1	P2	D0	E	F
8± 0.1	4± 0.1	4± 0.1	2± 0.05	1.5± 0.1	1.75± 0.1	3.5± 0.05

/Reel Dimensions    mm

A	W1	W2	N	R
177.8	9.3± 0.3	11.2± 0.3	58.5± 0.2	13.5± 0.2

## /Barcode-Product-Label (BPL)

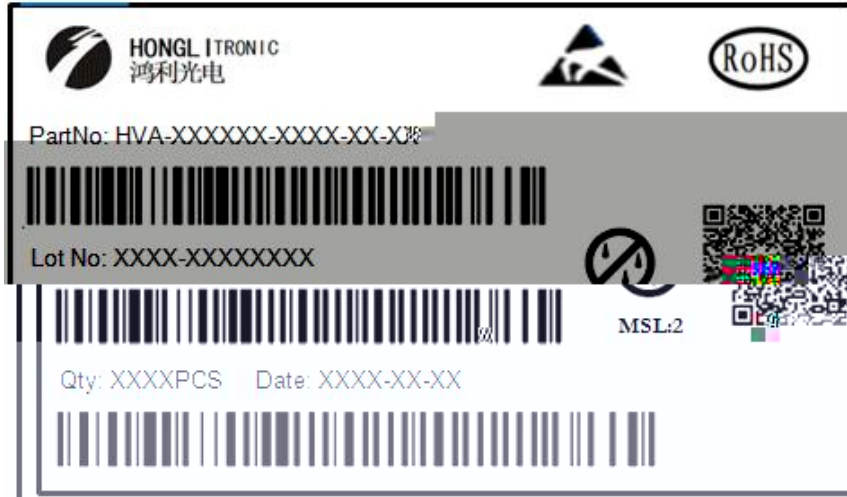

## /Dry Packing Process and Materials

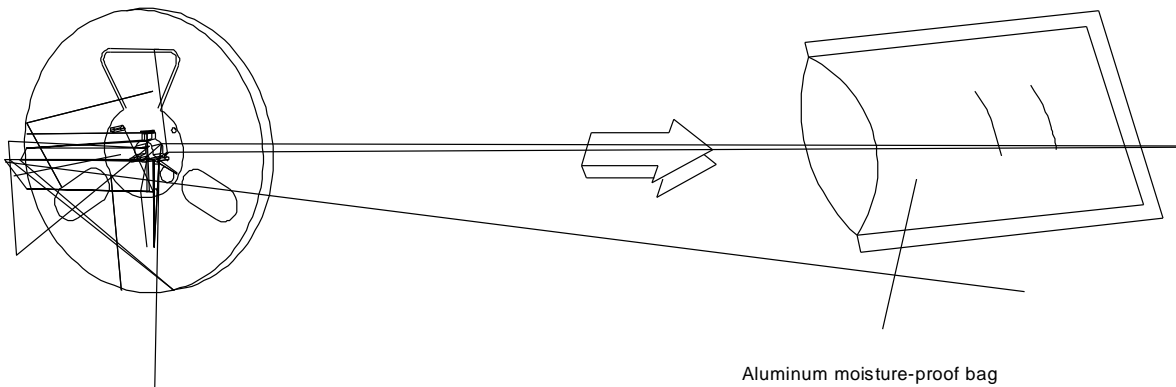

JEDEC

### NOTE

Moisture-sensitive product is packed in a dry bag containing desiccant and HIC (humidity indicator card). Regarding dry pack you may find further information in the internet or JEDEC.

## /Transportation Packing and Materials

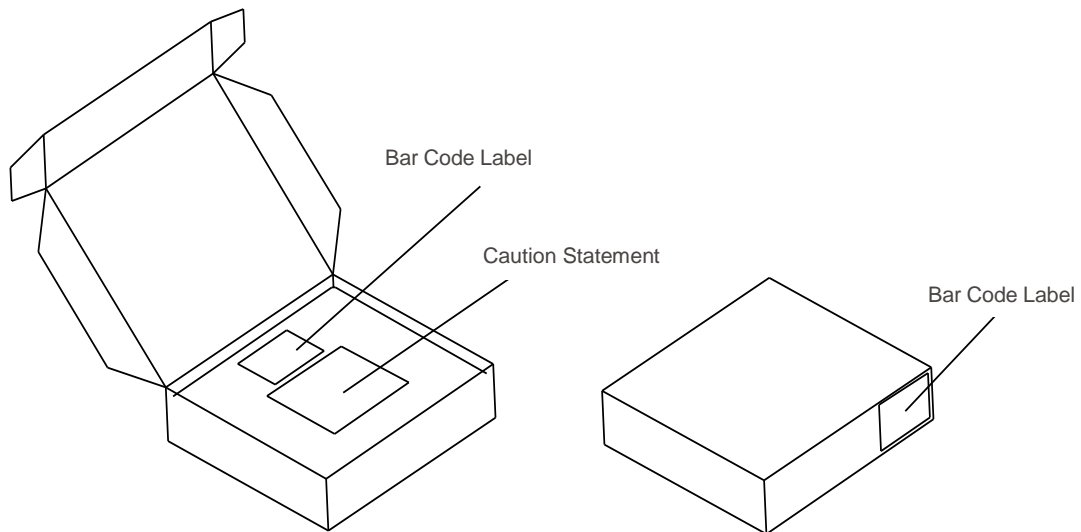

## /Dimensions of Transportation Box (mm)

/Width	/Length	/Height
256± 5	223± 5	62± 5
256± 5	223± 5	124± 5

:				
:		, ± 0.1 mm		
	8ms		± 0.05V	± 0.1V
	GUM K=3			
	25ms		± 0.5nm	± 1nm
	GUM K=3			
	25ms		± 8%	± 11%
	GUM K=3			

## Glossary

Typical Values, T EMC /P /MCID 62 BDC 7ET EMC /P /MCID 65/L