

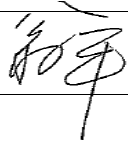



	●



Client approval		Hongli ZhiHui approval		
		  		

Adr NO.1,Xianke Yi Road,Huadong Town,, Huadu District, Guangzhou, China

Tel/ 020-86733333 Fax/ 020-86733883 86733938 86733265

- 1.
- 2.
- 3.
- 4.



	●



ATTENTION
OBSERVE PRECAUTIONS
FOR HANDLING
ELECTROSTATIC
DISCHARGE
SENSITIVE
DEVICES

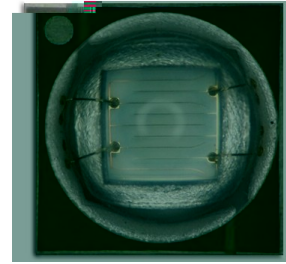

-
-
-
-
-
-
-

x x

Small size, Flexible design



...

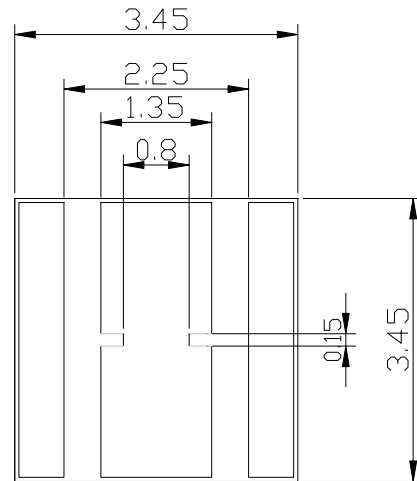
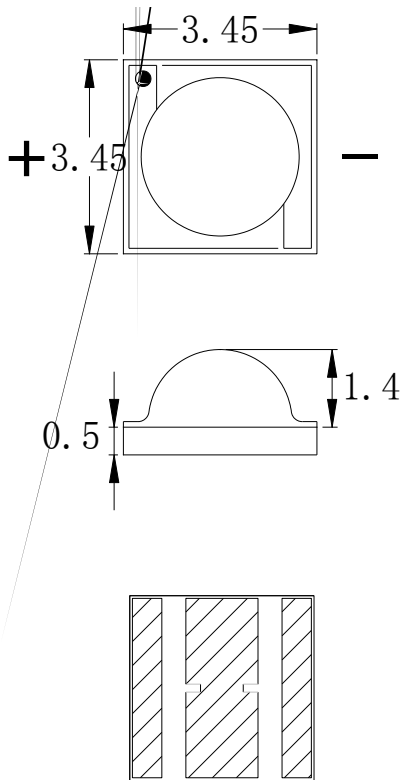



	●

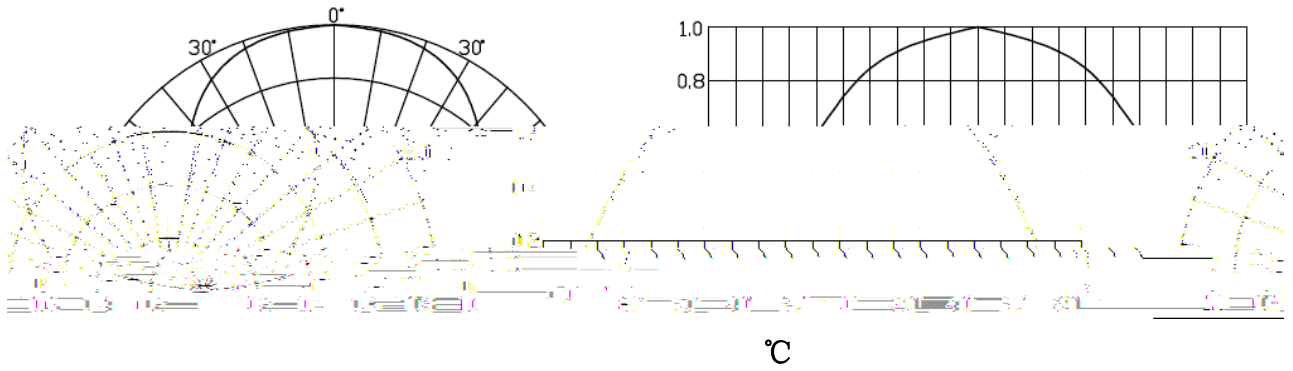

Φ

1/2

)

°C



	●

°C

Relative Luminous Flux - IF

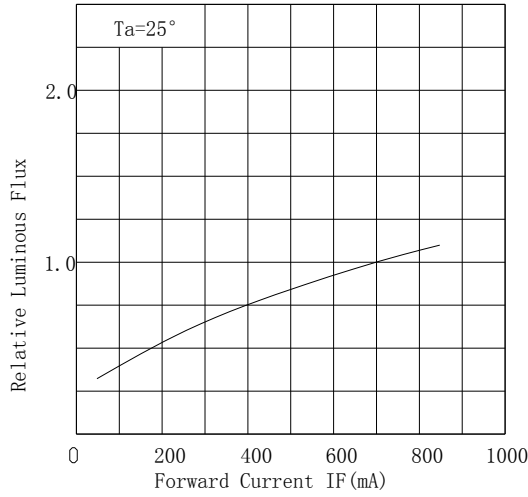

°C

Allowable Forward Current - Ta

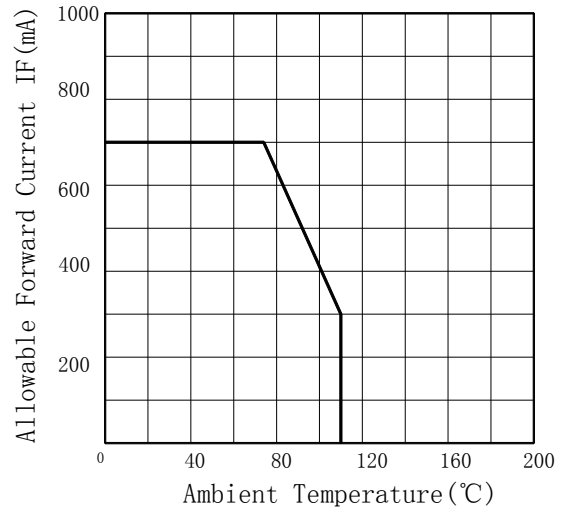

IF - VF

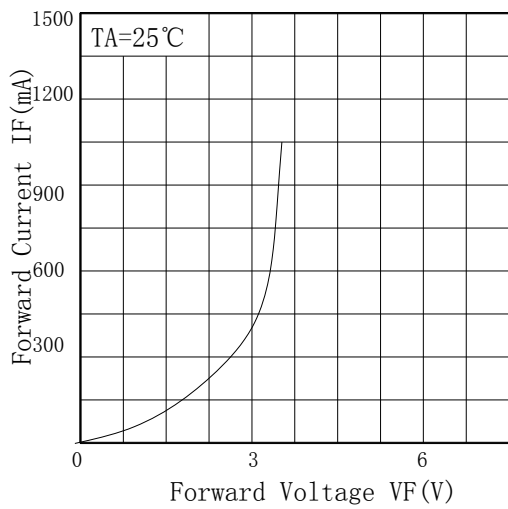

Relative Luminous Flux - Ta

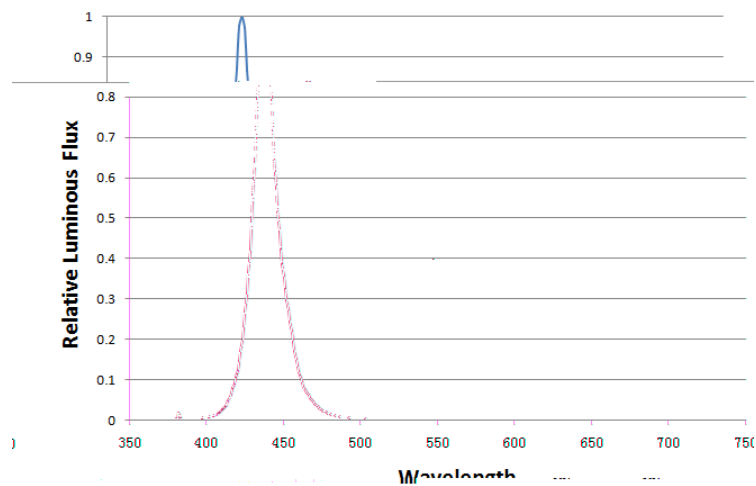
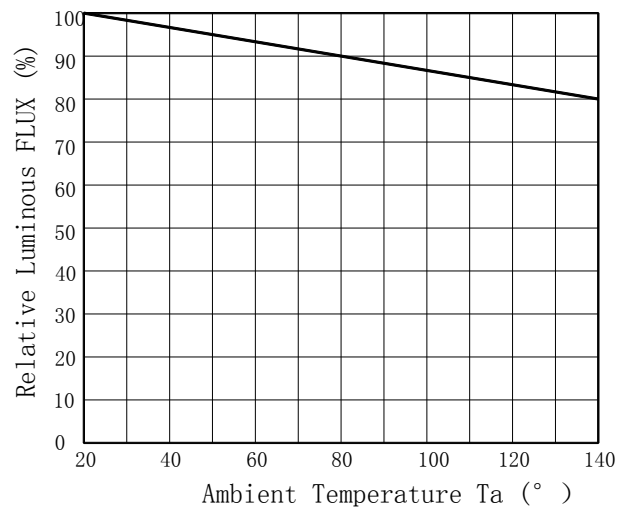



	●

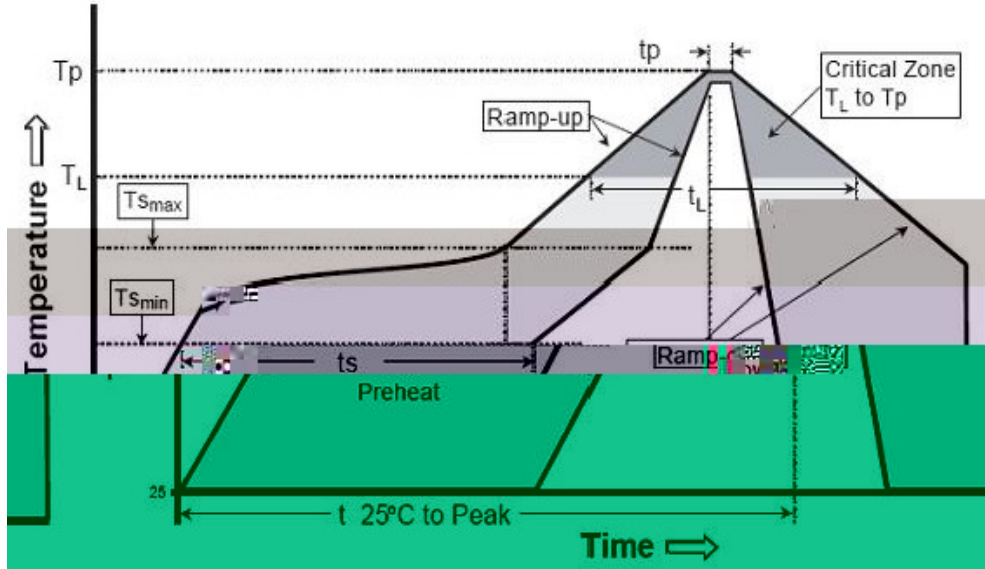

+ °C
+ °C 过

焊, 尽 对 进 复, 复, 请

焊 时, 挤压 头

焊, 将 进 压, 将焊 积, 头 挤压.

Pulse Width ≤ 10msec duty ≤ 1/10.

≤ ≤



	●

Φ

(:mm)

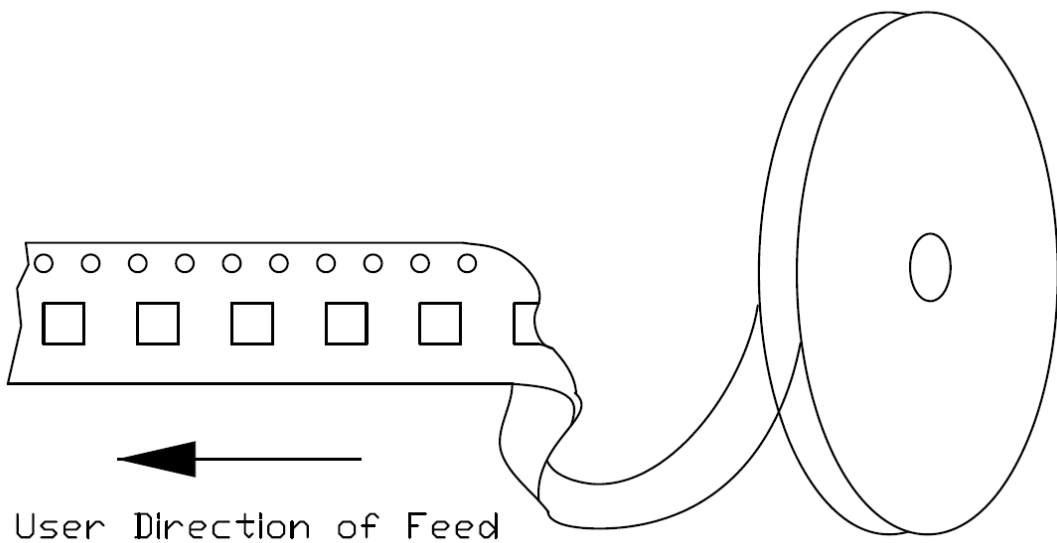
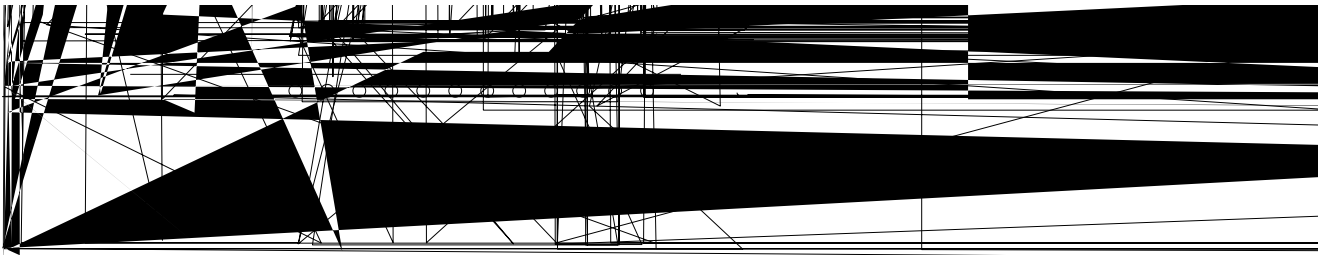



	●

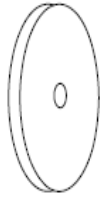

Reel: 2000pcs

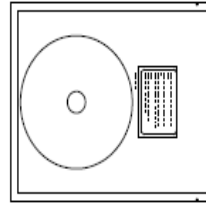
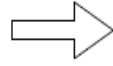

1Reel/ESD Shilding Bag

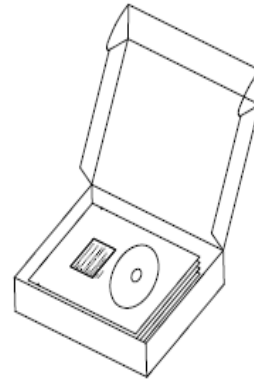
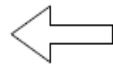
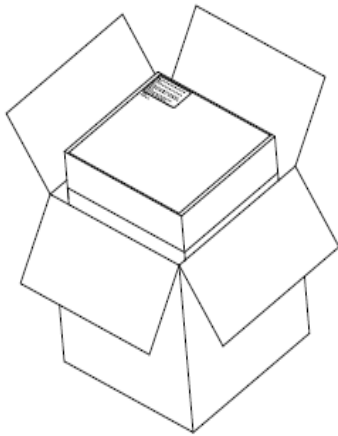

~~5 Inner Box/Outer Box: 50000pcs~~ ~~5Pcs/Inner box: 10000pcs~~

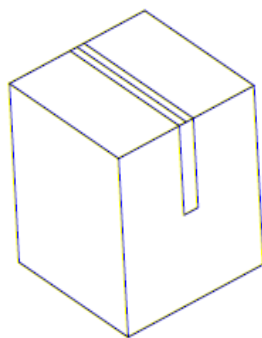

Outer Box 50000pcs





	●

()

).

: ~ ~ :

±

, °C

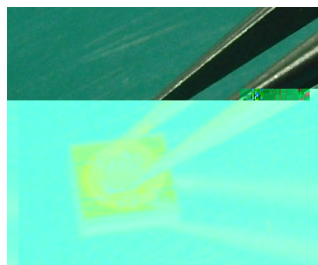
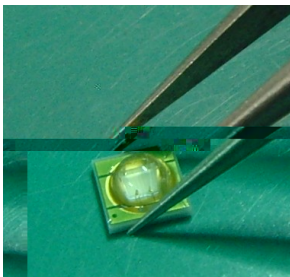



HONGLITRONIC
鸿利光电

	●

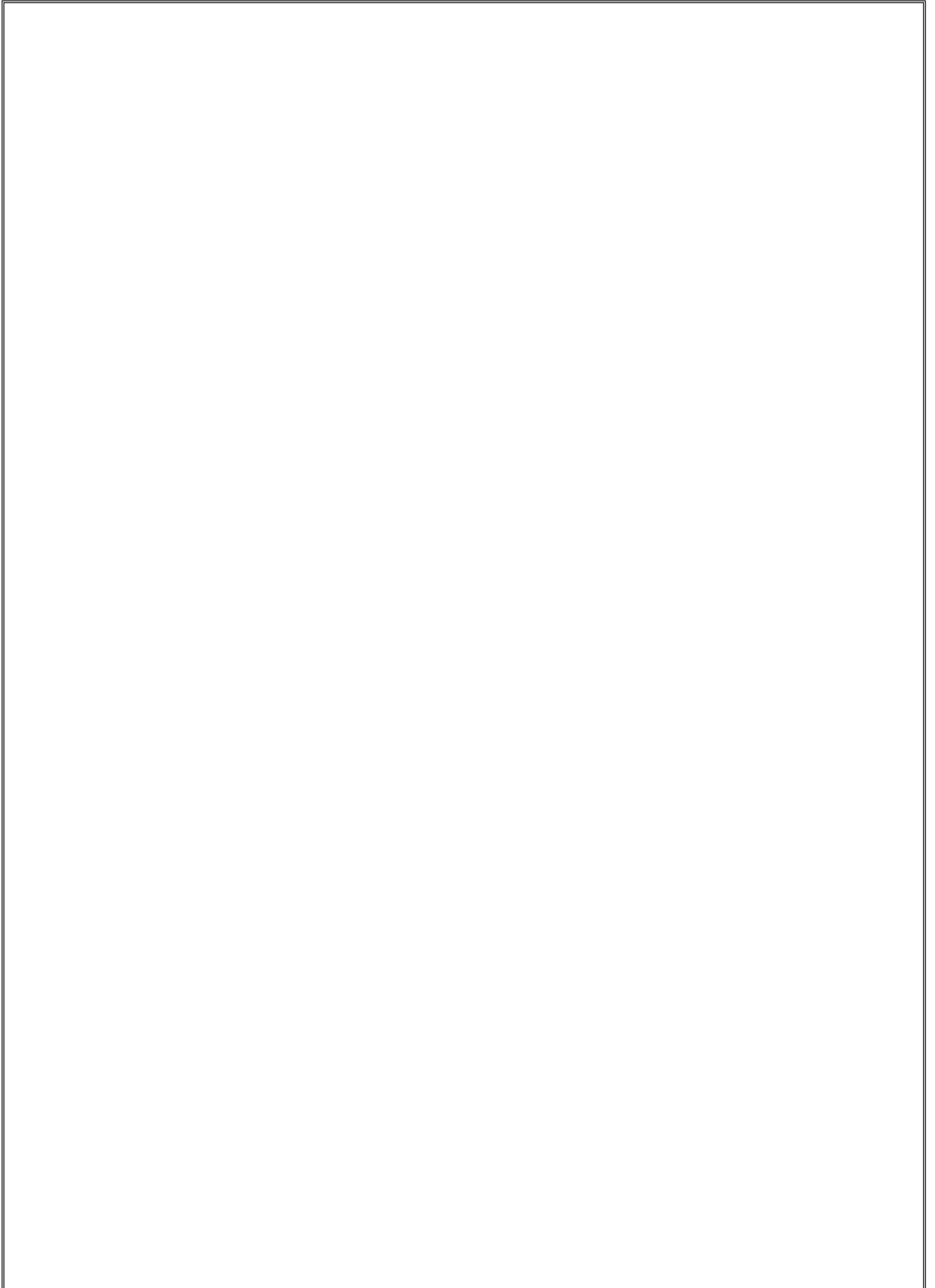



	●

1			2016. 06. 18	A/2
2				
3				
4				
5				
6				
7				
8				
9				
10				
11				
12				
13				
14				
15				
16				
17				
18				
19				
20				
21				
22				
23				
24				
25				
26				