



.

.

.

.

!

!

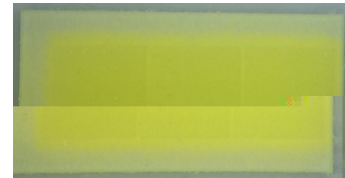

两

Cathode

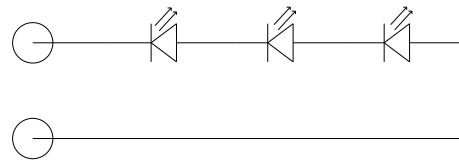

Anode



**ATTENTION**  
OBSERVE PRECAUTIONS  
FOR HANDLING  
ELECTROSTATIC  
DISCHARGE  
SENSITIVE  
DEVICES

低





HONGLIZHIHUI  
鸿利智汇

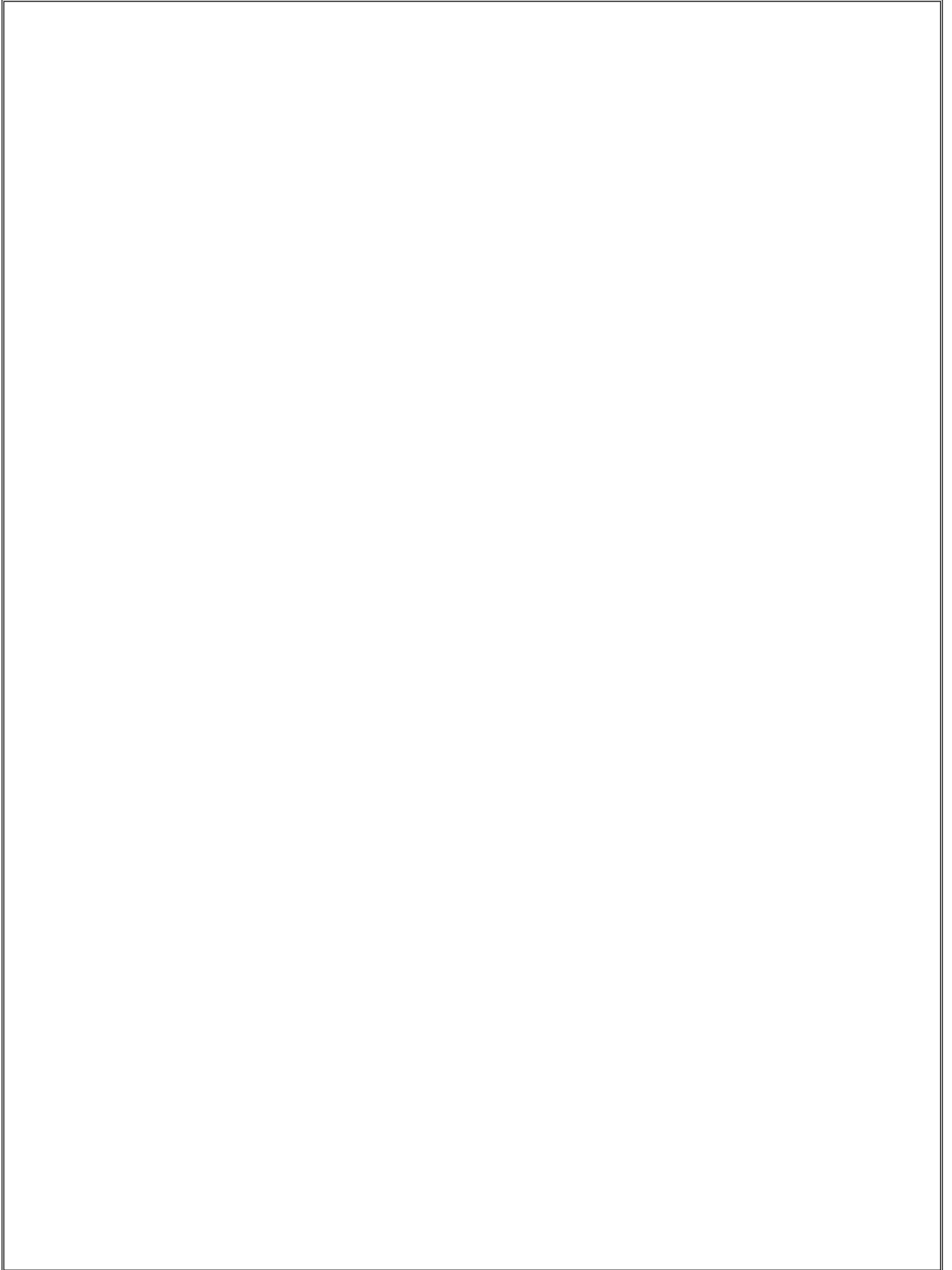



			升
	—		degrees
低		°	

注:

利

东



HONGLIZHIHUI  
鸿利智汇

注意事项:

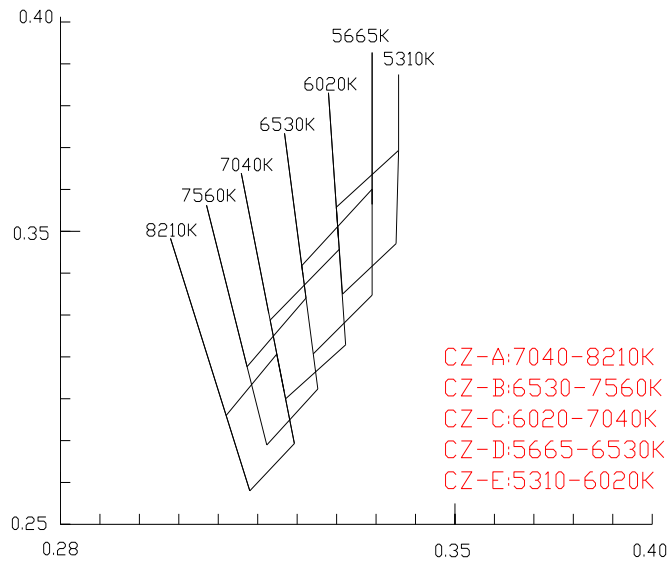

	!	!	!	!	!
	!	!	!	!	!

Notes

2.



### 典型光学/电性特征曲线 ( $T_a=25^{\circ}\text{C}$ 除非另有注释)

Relative Luminous Flux-IF

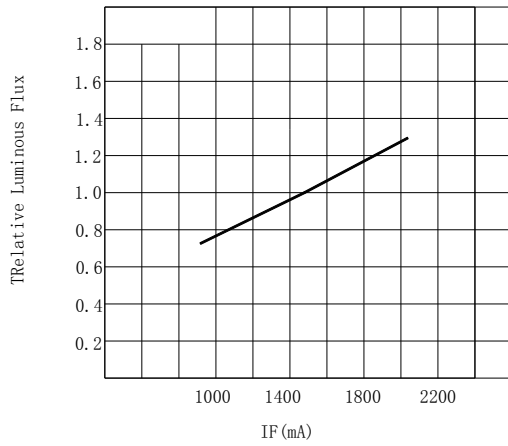

Relative Luminous Flux - Ts(base)

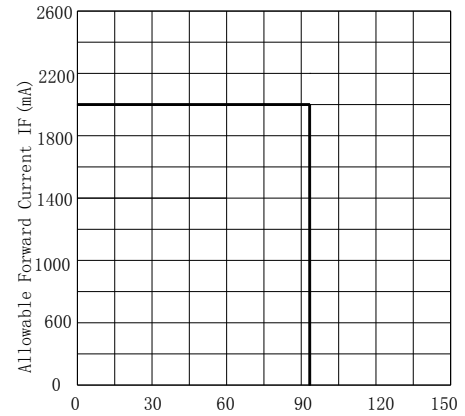

IF - VF

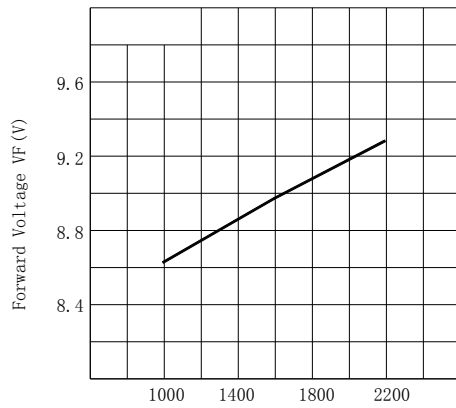

TJ - Relative Flux

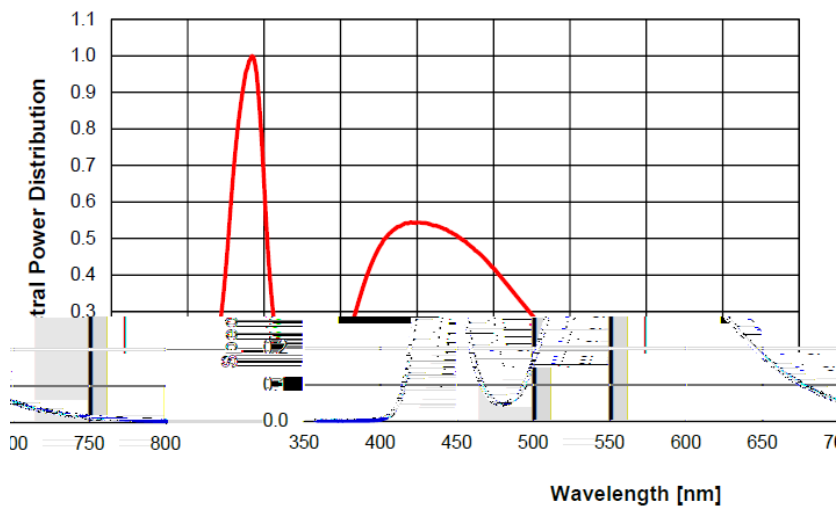
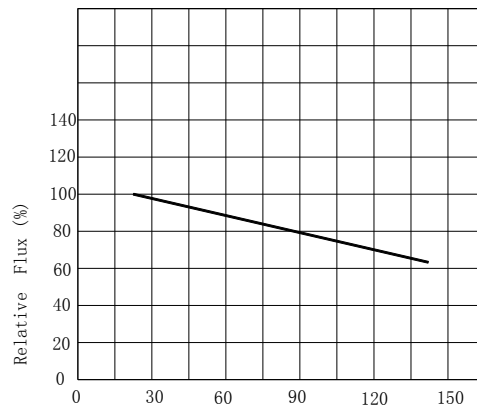



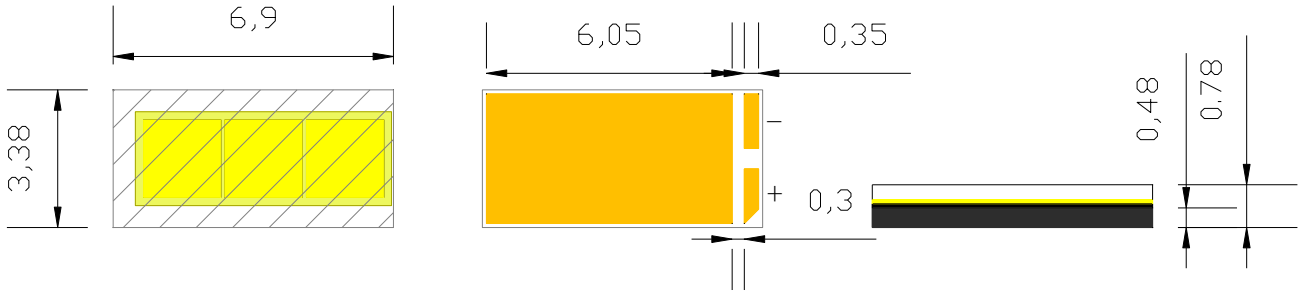

升

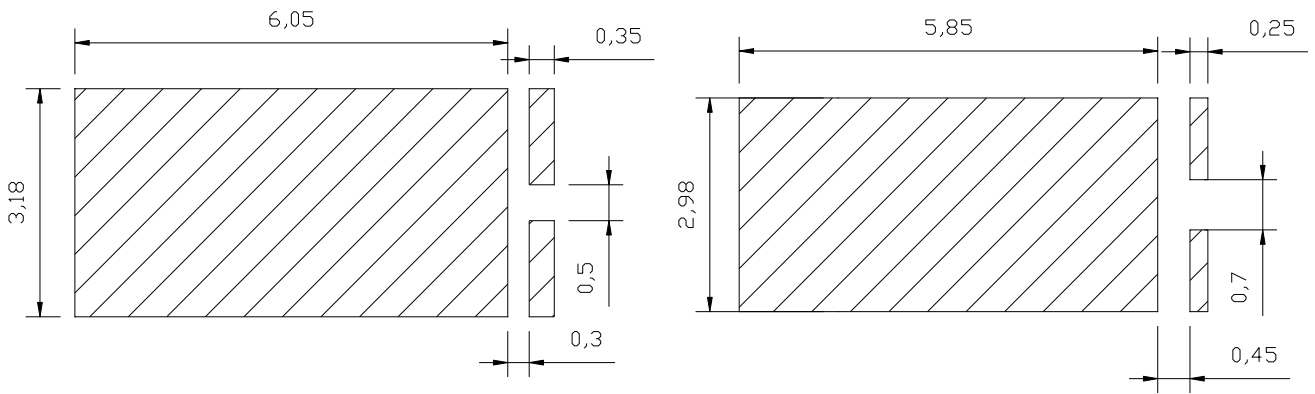

低



:

Φ



HONGLITRONIC  
鸿利光电

RoHS

TYPE:

QTY:

VF:

IF:

ΦV:

TC:

X/Y:

SDCM:

Total:

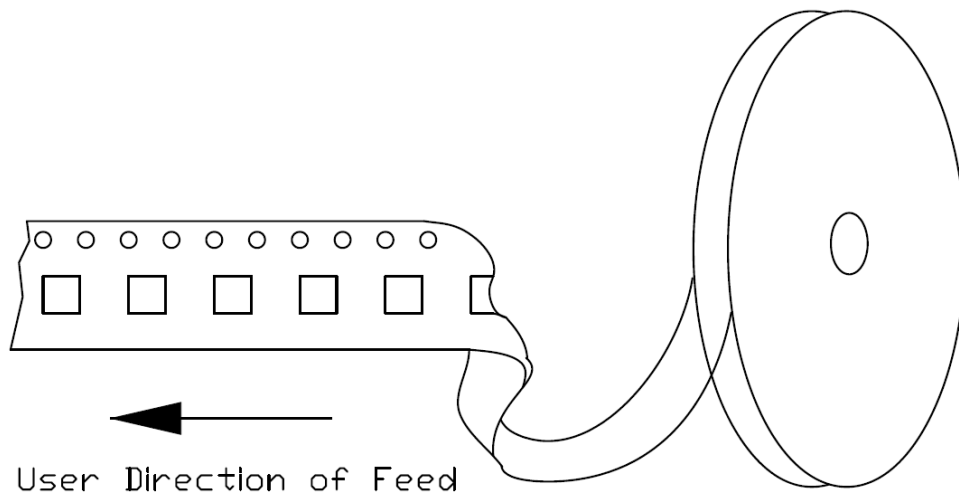



		°C		°C
			°C	°C
			°C	°C
			°C	°C
			°C	°C
	°C			
		°C		°C
°C				

Note:

145°-165°-185°-210°-220°-240°-260°-240

90cm/min

低



具

低  
低

低

低

)

升

东

入

)



全

低

两

低



Test	Test Conditions	Test Duration	Decision criteria	Units Failed/ Tested
	25°C 2000mA 1008H		$VF \leq 1.1VF$	
!	85°C 2000mA 1008H		$VF \leq 1.1VF$	
	85°C 85%RH 2000mA 1008H		$VF \leq 1.1VF$	
	! 40°C!! 100°C			
	! 40°C!! 100°C			



HONGLIZHIHUI  
鸿利智汇

具